



# Operation Manual

## CHV180 Series Special Inverter for Elevators



# Content

|   |           |
|---|-----------|
| <b>Content</b> .....                              | <b>1</b>  |
| <b>Safety precautions</b> .....                   | <b>3</b>  |
| <b>1. General</b> .....                           | <b>4</b>  |
| 1.1 General technical specifications.....         | 4         |
| 1.2 Description of name plate.....                | 5         |
| 1.3 Selection guide.....                          | 5         |
| 1.4 Parts description.....                        | 6         |
| 1.5 Description of extension card.....            | 7         |
| <b>2. Unpacking inspection</b> .....              | <b>9</b>  |
| <b>3. Disassembly and installation</b> .....      | <b>10</b> |
| 3.1 Environmental requirement.....                | 11        |
| <b>4. Wiring</b> .....                            | <b>12</b> |
| 4.1 Connections of peripheral devices.....        | 13        |
| 4.2 Terminal configuration.....                   | 13        |
| 4.3 Typical wiring diagram.....                   | 15        |
| 4.4 Wiring the main circuits.....                 | 15        |
| 4.5 Wiring control circuit terminals.....         | 18        |
| 4.6 Installation guideline to EMC compliance..... | 20        |
| <b>5. Operation</b> .....                         | <b>24</b> |
| 5.1 Operating keypad description.....             | 24        |
| 5.2 Operation process.....                        | 26        |
| 5.3 Running state.....                            | 28        |
| <b>6. Detailed function description</b> .....     | <b>30</b> |
| 6.1 P0 Group--Basic function.....                 | 30        |
| 6.2 P1 Group--Speed curve.....                    | 36        |
| 6.3 P2 Group--Motor parameters.....               | 43        |
| 6.4 P3 Group--Vector control.....                 | 45        |
| 6.5 P4 Group -- Encoder parameter.....            | 48        |
| 6.6 P5 Group--Input terminals.....                | 50        |
| 6.7 P6 Group -- Output terminals.....             | 55        |
| 6.8 P7 Group --Human-Machine interface.....       | 61        |
| 6.9 P8 Group --Enhanced function.....             | 66        |
| 6.10 P9 Group -- Protection parameters.....       | 71        |
| 6.11 PA Group --Serial communication.....         | 73        |
| 6.12 Pb Group -- Display monitor.....             | 76        |
| 6.13 PC Group --Load starting parameters.....     | 77        |

|   |            |
|---|------------|
| 6.14 Pd Group –Factory Setting .....                              | 79         |
| <b>7. Extension card .....</b>                                    | <b>80</b>  |
| 7.1 Description of communication card .....                       | 80         |
| 7.2 Description of I/O extension card .....                       | 81         |
| 7.3 Description of asynchronous motor PG card .....               | 83         |
| 7.4 Description of PG card for synchronous motor .....            | 87         |
| <b>Encoder voltage .....</b>                                      | <b>87</b>  |
| <b>8. Trouble shooting .....</b>                                  | <b>91</b>  |
| 8.1 Fault and trouble shooting .....                              | 91         |
| 8.2 Common faults and solutions .....                             | 96         |
| <b>9. Maintenance .....</b>                                       | <b>97</b>  |
| 9.1 Daily maintenance .....                                       | 97         |
| 9.2 Periodic maintenance .....                                    | 97         |
| 9.3 Replacement of wearing parts .....                            | 98         |
| <b>10. Communication protocol .....</b>                           | <b>99</b>  |
| 10.1 Interfaces .....   | 99         |
| 10.2 Communication modes .....                                    | 99         |
| 10.3 Protocol format .....  | 99         |
| 10.4 Protocol function .....                                      | 100        |
| 10.5 Note .....   | 104        |
| 10.6 CRC check .....  | 105        |
| 10.7 Example .....  | 105        |
| <b>Appendix A: Commissioning guide.....</b>                       | <b>111</b> |
| A.1 Runing and parameter-adjusting.....                           | 111        |
| A.2 Elevator running mode .....                                   | 112        |
| <b>Appendix B: Dimension of the inverter .....</b>                | <b>123</b> |
| B.1 External dimension .....                                      | 123        |
| B.2 Dimensions of external keypad .....                           | 124        |
| B.3 Installation space .....                                      | 125        |
| B.4 Disassembly and installation .....                            | 126        |
| <b>Appendix C: Specification of accessories.....</b>              | <b>127</b> |
| C.1 Specifications of breaker, cable, contactor and reactor ..... | 127        |
| C.2 Braking resistor/unit selection .....                         | 128        |
| <b>Appendix D Function parameters.....</b>                        | <b>130</b> |

## Safety precautions

Please read this operational manual carefully before installation, operation, maintenance or inspection.

The precautions related to safe operation are classified into “WARNING” and “CAUTION”.



**WARNING**

Points out potential danger which, if not avoided, may cause physical injury or death.



**CAUTION**

Points out potential danger which, if not avoided, may result in mild or moderate physical injury and damage to the equipment. It's also available to warns about unsafe operations.

In some cases, even the content described in “CAUTION” may also cause serious accidents. So please follow these important precautions in any situations.

★ **NOTE** is the necessary step to ensure the proper operation.

Warning signs are presented on the front cover of inverters.

Please follow these instructions when using the inverter.

### WARNING

- May cause injury or electric shock.
- Please follow the instructions in the manual before installation or operation.
- Disconnect all power line before opening front cover of unit. Wait at least 5 minute until DC Bus capacitors discharge.
- Use proper grounding techniques.
- Never connect AC power to output UVW terminals

# 1. General

## 1.1 General technical specifications

### • Input & output

- ◆ Input voltage range: 380V±15%
- ◆ Input frequency range: 47~63Hz
- ◆ Output voltage range: 0~rated input voltage
- ◆ Output frequency range: 0~400Hz

### • I/O features

- ◆ Programmable digital input: Provide 6 terminals which can accept ON-OFF inputs and 4 inputs can be extended by I/O extension card.
- ◆ Programmable analog input: AI1 can accept input of 0~10V, AI2 can accept input of 0~10V or 0~20mA.
- ◆ Programmable open collector output: Provide 1 output terminal, another 1 output can be extended by I/O card.
- ◆ High speed pulse output: Provide 1 output terminal, which can be changed as open collector output or high speed pulse output through the related functional code.
- ◆ Relay output: Provide 2 output terminals, 1 output can be extended by I/O extension card.
- ◆ Analog output: 1 output terminal, 0~20 mA or 0~10 V. another 1 can be extended by I/O extension card.

### • Main control function

- ◆ Control mode: Sensorless vector control (SVC), Vector control with PG (VC), V/F control.
- ◆ Overload capacity: 60s with 150% of rated current, 10s with 180% of rated current.
- ◆ Starting torque: 150% of rated torque at 0.5Hz (SVC); 180% of rated torque at 0Hz (VC).
- ◆ Speed adjusting range: 1:100 (SVC); 1:1000 (VC)
- ◆ Speed accuracy: ± 0.5% of maximum speed (SVC); ±0.1% of maximum speed (VC)
- ◆ Carrier frequency: 1.0 kHz~16.0 kHz.

### • Functions

- ◆ Frequency reference source: Digital input, analog input, serial communication, multi-step speed and analog tracking running.
- ◆ Operating mode: Checking running, emergency running and decelerating running.

- ◆ Elevator control logic: Internal contracting brake, contactor control.
- ◆ Pre-torque compensation at starting moment without weighing sensor. (only for the SIN / COS encoder)
- ◆ Pre-torque compensation at starting moment with weighing sensor
- ◆ Identificate synchronous machine's initial angle of magnetic pole in static (only for the SIN / COS Encoder)
- ◆ DC braking at starting and stopping
- ◆ PG Card (optional parts): SIN/COS synchronous motor PG Card, U/VW synchronous motor PG Card, asynchronous motor PG Card.
- ◆ Automatic voltage regulation (AVR): Automatically keep the output voltage stable when input voltage fluctuating.

Up to 30 fault protections: Protect from overcurrent, over voltage, under voltage, phase failure, over load, speeding etc.

### 1.2 Description of name plate

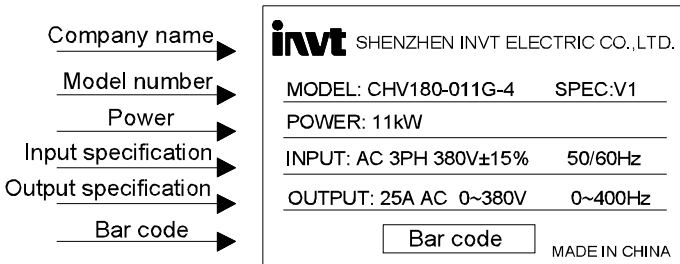

Figure 1.1 Nameplate of inverter

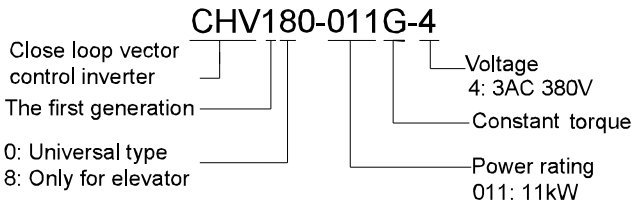

Figure 1.2 Meaning of the model number

### 1.3 Selection guide

**3AC 380V ±15%**

| Model No.     | Rated power (kW) | Rated input current (A) | Rated output current (A) | Size |
|---------------|------------------|-------------------------|--------------------------|------|
| CHV180-004G-4 | 3.7              | 10.0                    | 9.0                      | C    |
| CHV180-5R5G-4 | 5.5              | 15.0                    | 13.0                     | C    |
| CHV180-7R5G-4 | 7.5              | 20.0                    | 17.0                     | D    |
| CHV180-011G-4 | 11.0             | 26.0                    | 25.0                     | D    |
| CHV180-015G-4 | 15.0             | 35.0                    | 32.0                     | D    |
| CHV180-018G-4 | 18.5             | 38.0                    | 37.0                     | E    |
| CHV180-022G-4 | 22.0             | 46.0                    | 45.0                     | E    |
| CHV180-030G-4 | 30.0             | 62.0                    | 60.0                     | E    |

### 1.4 Parts description

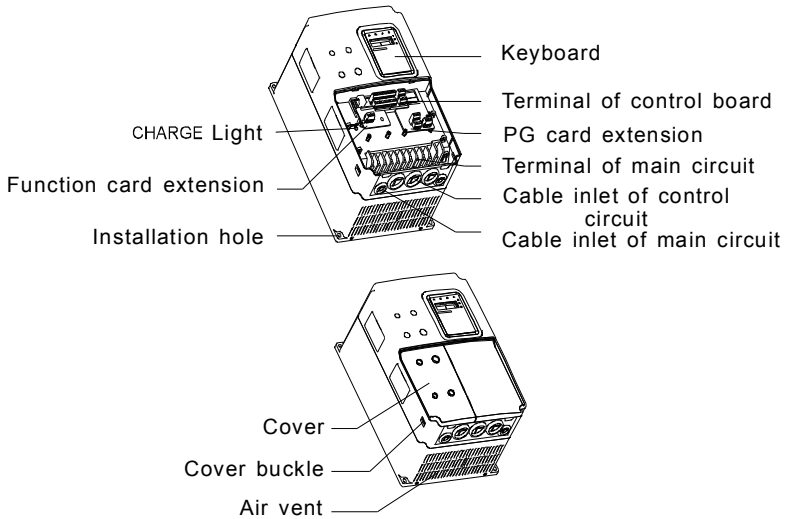

Figure 1.3 Parts of inverter (15kw and below)

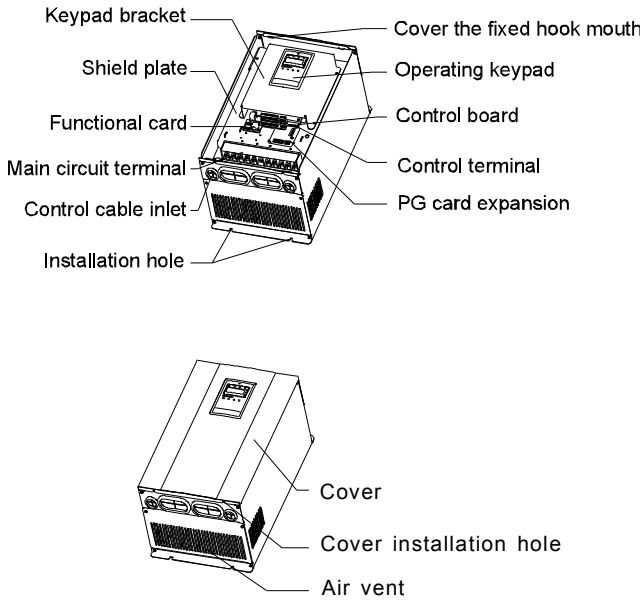

Figure 1.4 Parts of inverters (18.5KW and above)

### 1.5 Description of extension card

Following extension cards can be installed in CHV180 series inverters:

| Extension Card               | Description  |
|------------------------------|--|
| Serial communication card    | 1. Offer RS232 and RS485 dual physical communication interface, two communication mode can be switched by short-connecting module.<br>2. RS232 interface adopts standard DB9 female connector in order to the convenient connection.<br>3. Open 3-hole interface.<br>4. Embedded Modbus standard protocol. |
| PG Card (asynchronous motor) | 1. Receive high-speed pulse from encoder to realize high-accuracy close-loop vector control.<br>2. Both push-and-pull input and open-circuit collector input.  |



| <b>Extension Card</b>                  | <b>Description</b>  |
|--|---|
|  | 3. Offer frequency division output, the frequency division factor can be selected by dial switch.   |
| SIN/COS PG Card<br>(synchronous motor) | Receive high-speed pulse from encoder to realize high- accuracy close-loop vector control.<br>SIN/COS PG Card compatible with SIN/COS encoder.<br>Frequency division is 1, which can not be changed.                                    |
| UVW PG Card<br>(synchronous motor)     | Receive high-speed pulse from encoder to realize high- accuracy close-loop vector control.<br>UVW PG Card compatible with U/V/W encoder. Offer frequency division output, the frequency-division factor can be selected by dial switch. |
| I/O Extension Card                     | Offer more input/output terminals to enhance the external function of inverter. RS485 port is available.  |

Please refer to chapter 7 for more detailed information.

## 2. Unpacking inspection



### CAUTION

**•Don't install or use any inverter that is damaged or has fault parts, otherwise physical injury may occur**

Check the following items after unpacking the inverter:

1. Inspect the entire exterior of the inverter to ensure there are no scratches or other damage caused by the transportation.
2. Ensure there is operation manual in the packing box.
3. Inspect the nameplate and ensure it is the ordered product.
4. Ensure the optional parts are the ordered ones.

Please contact the local agent if there is any damage to the inverter or optional parts.

### 3. Disassembly and installation



#### WARNING

- Only qualified electricians are allowed to operate on the drive device/system. Ignoring the instructions in “warning” may cause serious physical injury or death or property loss.
- Connect the input power lines tightly and permanently. And ground the device with proper techniques.
- Even when the inverter is stopped, dangerous voltage is present at the terminals:
  - Power Terminals: R, S, T
  - Motor Connection Terminals: U, V, W.
- Stop the drive and disconnect it from the power line. Wait for 10 minutes to let the drive discharge and then begin the installation.
- Minimum cross-sectional areas of the grounding conductor should be at least 10m<sup>2</sup>. Or select the larger one between the cross-sectional area of the power cord conductors and the cross-sectional area of the grounding conductor according to the following table:

| the cross-sectional areas of power cord conductors m <sup>2</sup> | the cross-sectional areas of grounding conductors m <sup>2</sup> |
|---|--|
| S≤16  | S  |
| 16<S≤35   | 16   |
| 35<S  | S/2  |



#### CAUTION

- Life the inverter by its base other than the keypad or the cover. The dropping of the main part may cause physical injury.
- The inverter is fixed on a non-flammable wall such as metal and away from heat and flammable materials to avoid the fire.
- If more than two drives are installed in a cabinet, the temperature should be lower than 40°C by means of a cooling fan. Overheat may cause fire or damage to the drive.

### 3.1 Environmental requirement

#### 3.1.1 Temperature and Humidity

The ambient temperature is among -10 °C to 40 °C and the inverter has to derate by 4% for every additional 1 °C if the ambient temperature exceeds 40 °C. The temperature cap is 50 °C.

Relative humidity of the air:  $\leq 90\%$ . No condensation is allowed.

#### 3.1.2 Altitude

The inverter can run at the rated power if the installation site is less than 1000m (including 1000m) above the sea level. But it has to derate if the altitude exceeds 1000m.

See the following figure for details:

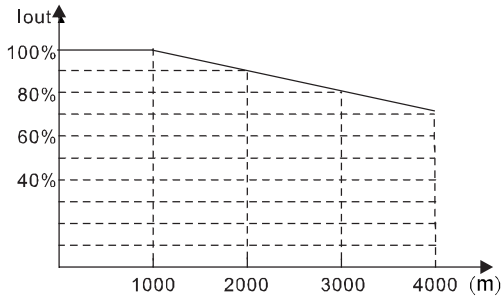

Figure 3.1 Relationship between output current and altitude

#### 3.1.3 Other environment requirements

The inverter can not bear fierce impact or shock. So the oscillation range should be less than  $5.88\text{m/s}^2$  (0.6g), 10Hz~60Hz.

The inverter should keep away from the electromagnetic radiation source.

The inverter should keep away from water and condensation.

The inverter should keep away from contaminative air, such as corrosive gas, oil mist and conductive dust.

The inverter should keep away from direct sunlight, oil mist, and steam and vibration environment.

## 4. Wiring



### WARNING

- Only qualified electricians are allowed to operate on the drive for the insurance of a safe running of the inverter.
- Never carry out any insulation or voltage withstand tests on the cables connecting with the inverter.
- Even if the servo drive is stopped, dangerous voltage is present at the input power lines, DC circuit terminals and motor terminals. Wait for 10 minutes even when the inverter is switched off until is discharge before operation.
- Ground the grounding terminals of the inverter with proper techniques. The grounding resistor will be less than **10Ω**. Otherwise there is danger of electrical shock and fire.
- Do not connect the 3 phase power supply to the output terminals of the inverter (U, V, and W), otherwise damage may occur to the inverter.
- Please ensure right connection between the power wires and the motor wires. The power wire is connected with the terminals of R, S and T. And the motor wire is connected with the terminals of U, V and W.
- Never do wiring or other operations on the inverter with wet hands. Otherwise there is danger of electric shock



### CAUTION

- Verify that the rated voltage of the servo drive equals to the voltage of the AC power supply.
- The power wires and motor wires must be permanently fastened and connected.

### 4.1 Connections of peripheral devices

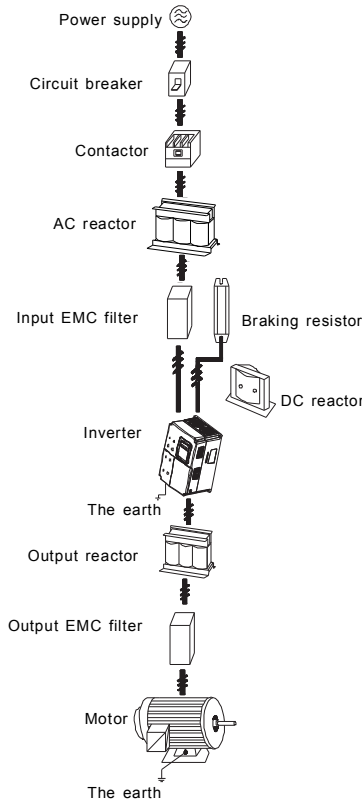

Figure 4.1 Connections of peripheral devices.

### 4.2 Terminal configuration

#### 4.2.1 Main circuit terminals (380VAC)

|     |    |     |       |   |   |       |   |   |   |
|-----|----|-----|-------|---|---|-------|---|---|---|
| (+) | PB | (-) | R     | S | T | U     | V | W | ⊕ |
|     |    |     | POWER |   |   | MOTOR |   |   |   |

Figure 4.2 Main circuit terminals (4~5.5kW)

|   |     |    |       |   |   |       |   |   |   |   |
|---|-----|----|-------|---|---|-------|---|---|---|---|
| ⊕ | (+) | PB | (-)   | R | S | T     | U | V | W | ⊕ |
|   |     |    | POWER |   |   | MOTOR |   |   |   |   |

Figure 4.3 Main circuit terminals (7.5~15kW).

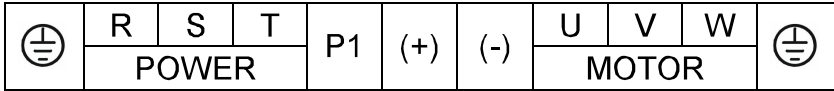



Figure 4.4 Main circuit terminals (18.5~30kW).

Functions instruction:

| Terminal  | Description                                  |
|---|--|
| R, S and T  | Terminals of 3 phase AC input                |
| (+) and (-)   | Spare terminals of external braking unit     |
| (+) and PB  | Spare terminals of external braking resistor |
| P1 and (+)  | Spare terminals of external DC reactor       |
| (-)   | Terminal of negative DC bus                  |
| U, V and W  | Terminals of 3 phase AC output               |
|  | Terminal of gnd                              |

**4 2 2. Control circuit terminals**

|      |    |     |    |     |     |     |     |     |      |  |      |      |      |
|------|----|-----|----|-----|-----|-----|-----|-----|------|--|------|------|------|
| S1   | S2 | S3  | S4 | S5  | S6  | GND | AI1 | AI2 | +10V |  | RO1A | RO1B | RO1C |
| +24V | PW | COM | Y1 | CME | COM | HDO | AO1 | GND | PE   |  | RO2A | RO2B | RO2C |

Figure 4.5 Control circuit terminals.

### 4.3 Typical wiring diagram

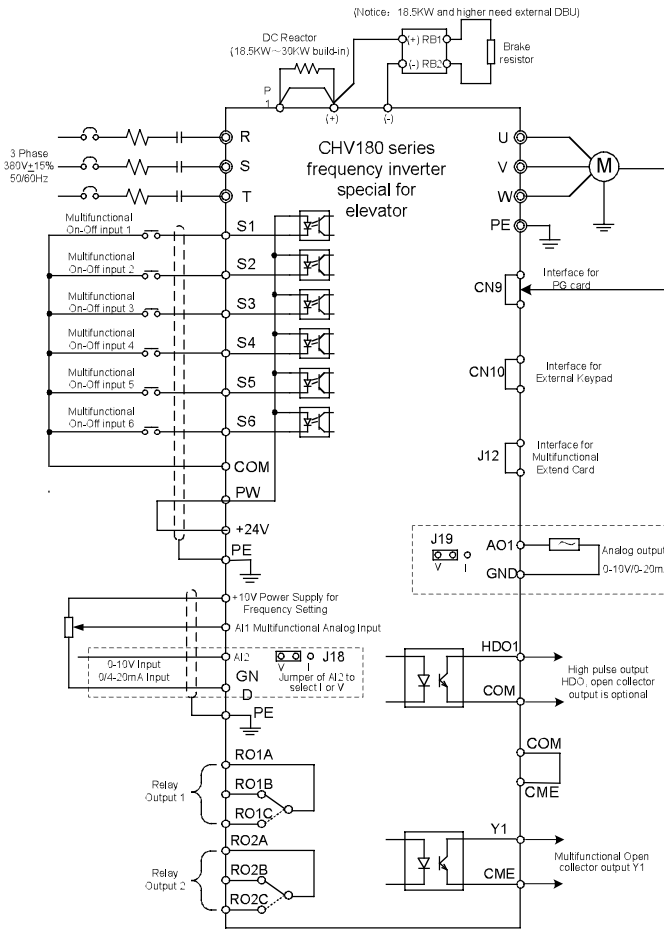

Figure4. 6 Wiring diagram.

### 4.4 Wiring the main circuits

#### 4.4.1 Wiring at the side of power supply

##### 4.4.1.1 Circuit breaker

It is necessary to connect a circuit breaker which is compatible with the capacity of inverter between 3ph AC power supply and power input terminals (R, S and T). The capacity of breaker is 1.5~2 times to the rated current of inverter. Please refer to the chapter of **Specifications of Breaker, Cable, and Contactor** for details.

##### 4.4.1.2 Contactor



In order to cut off the input power effectively when something is wrong in the system, contactor should be installed at the input side to control the ON-OFF of the main circuit power supply.

#### ●4.4.1.3 AC reactor

In order to prevent the rectifier damage result from the large current, AC reactor should be installed at the input side. It can also prevent rectifier from sudden variation of power voltage or harmonic generated by phase-control load.

#### ●Input EMC filter

The surrounding device may be disturbed by the cables when the inverter is working. EMC filter can minimize the interference. Just like the following figure.

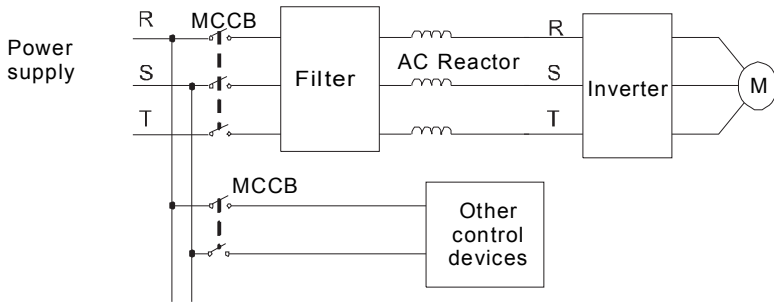

Figure 4.7 Wiring at input side.

### 4.4.2 Wiring for inverter

#### ●4.4.2.1 DC reactor

CHV180 inverters (18.5kW~30kW) are equipped with internal DC reactors for the improvement of power factors and the avoidance of damage from high input current to the rectifying components because of the high-capacity transformer. The device can also cease the damage to the rectifying components which are caused by supply net voltage transients and harmonic waves of the loads.

#### ●4.4.2.2 Braking unit and braking resistor

Inverters of 15kW and below have built-in braking unit. In order to dissipate the regenerative energy generated by dynamic braking, the braking resistor should be installed at (+) and PB terminals. The wire length of braking resistor should be less than 5m.

- Inverters of 18.5kW and above need connect external braking unit which should be installed at (+) and (-) terminals. The cable between inverter and braking unit should be less than 5m. The cable between braking unit and braking resistor should be less than 10m.
- The temperature of the braking resistor will increase because of the released energy. Safety protection and good ventilation is recommended during the installation. If the braking unit is needed, (+) and (-) terminal of the braking correspond to the (+) and (-) terminal of the inverter and the braking resistor is connected to the terminal of BR1 and BR2.

**Note:** Be sure that the electric polarity of (+) (-) terminals is right; it is not allowed to connect (+) with (-) terminals directly, Otherwise damage or fire could occur.

#### 4.4.3 Wiring at motor side of main circuit

##### ●4.4.3.1 Output reactor

If the distance between the inverter and the motor is longer than 50m, frequent overcurrent protection may occur to the inverter because of high leakage current caused by parasitic capacitance effects from the long cables to the ground. In order to avoid the damage of the motor insulation, it is necessary to add reactor compensation.

##### ●4.4.3.2 Output EMC filter

EMC filter can minimize the radio noise cause by the cables between the inverter and the motor and the leakage current of the conducting wires, which is illustrated as below:

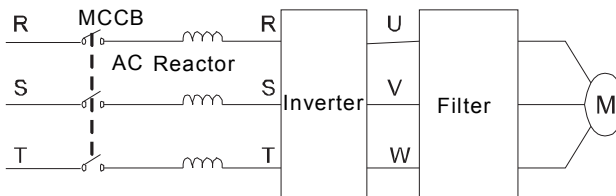

Figure 4.8 Wiring at motor side.

#### 4.4.4 Wiring of regenerative unit

Regenerative unit is used for putting the electricity generated by braking of motor to the grid. Compared with traditional 3 phase inverse parallel bridge type rectifier unit, regenerative unit uses IGBT so that the total harmonic distortion (THD) is less than 4%. Regenerative unit is widely used for centrifugal and hoisting equipment. Please refer to *The Manual of Regenerative Units of RBU Series* for details.

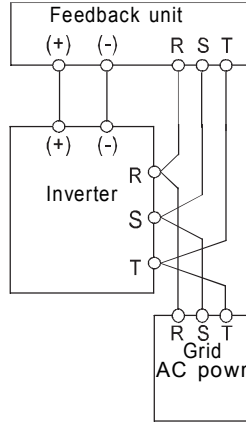

Figure 4.9 Wiring of regenerative unit.

**4.4.5 Ground wiring (PE)**

Ground the PE terminal of the inverter with grounding resistors (less than 10 Ω) for the insurance of safety and avoidance of electrical shock and fire. It is proper to use thick and short multiple copper core wires whose sectional area is larger than 3.5mm<sup>2</sup>. It is not recommended to use the public earth wire; otherwise, the grounding wires may complete the circuit.

**4.5 Wiring control circuit terminals**

**4.5.1 Precautions**

- Use shielded or twisted-pair cables to connect control terminals.
- Connect the ground terminal (PE) with shield wire.
- The cable connected to the control terminal should leave away from the main circuit and heavy current circuits (including power supply cable, motor cable, relay and contactor connecting cable) at least 20cm and parallel wiring should be avoided. It is suggested to apply perpendicular wiring to prevent inverter malfunction caused by external interference.

**4.5.2 Control circuit terminals**

| Terminal | Description   |
|----------|---|
| S1~S6    | ON-OFF signal input, optical coupling isolation input terminal with PW and COM.<br>Input voltage range: 9~30V<br>Input impedance: 3.3kΩ |
| PW       | External power supply. +24V terminal is connected to PW   |

| Terminal               | Description  |
|------------------------|--|
|                        | terminal as default setting. If user need external power supply, disconnect +24V terminal with PW terminal and connect PW terminal with external power supply.   |
| +24V                   | Provide output power supply of +24V.<br>Maximum output current: 150mA  |
| COM                    | Common ground terminal for digital signal and +24V (or external power supply).   |
| AI1                    | Analog input, 0~10V<br>Input impedance: 10k $\Omega$   |
| AI2                    | Analog input, 0~10V/ 0~20mA, switched by J18.<br>Input impedance:10k $\Omega$ (voltage input) / 250 $\Omega$ (current input)   |
| GND                    | Common ground terminal of analog signal and +10V.<br>GND must isolated from COM.   |
| Y1(Y2)                 | Open collector output terminal, the corresponding common ground terminal is CME.<br>External voltage range: 0~24V<br>Output current range: 0~50mA<br>24V pull-up resistor range: 2k $\Omega$ ~10k $\Omega$ |
| CME                    | Common terminal of open collector output   |
| +10V                   | Supply +10V for inverter.  |
| HDO                    | High speed pulse output terminal. The corresponding common ground terminal is COM.<br>Output frequency range: 0~50 kHz   |
| AO1(AO2)               | Provide voltage or current output which can be switched by J19.<br>Output range: 0~10V/ 0~20mA   |
| PE                     | Ground Terminal.   |
| RO1A, RO1B<br>and RO1C | RO1 relay output: RO1A—common; RO1B—NC; RO1C—NO.<br>Contact capacity: AC 250V/3A, DC 30V/1A.   |
| RO2A, RO2B<br>and RO2C | RO2 relay output: RO2A—common; RO2B—NC; RO2C—NO.<br>Contact capacity: AC 250V/3A, DC 30V/1A.   |
| RO3A, RO3B<br>and RO3C | RO3 relay output: RO3A—common; RO3B—NC; RO3C—NO.<br>Contact capacity: AC 250V/3A, DC 30V/1A.   |

#### 4.5.3 Jumper on control board

| Terminal                   | Description  |
|----------------------------|--|
| J2, J4, J5, J13<br>and J14 | They are prohibited to be changed, otherwise it will cause inverter malfunction.   |
| J18                        | Switch between (0~10V) voltage input and (0~20mA) current input.<br>V connect to GND means voltage input;<br>I connect to GND means current input.     |
| J19                        | Switch between (0~10V) voltage output and (0~20mA) current output.<br>V connect to OUT means voltage output;<br>I connect to OUT means current output. |

## 4.6 Installation guideline to EMC compliance

### 4.6.1 General knowledge of EMC

EMC is the abbreviation of electromagnetic compatibility, which means the device or system has the ability to work normally in the electromagnetic environment and will not generate any electromagnetic interference to other equipments.

EMC includes two subjects: electromagnetic interference and electromagnetic anti-jamming.

According to the transmission mode, Electromagnetic interference can be divided into two categories: conducted interference and radiated interference.

Conducted interference is the interference transmitted by conductor. Therefore, any conductors (such as wire, transmission line, inductor, capacitor and so on) are the transmission channels of the interference.

Radiated interference is the interference transmitted in electromagnetic wave, and the energy is inverse proportional to the square of distance.

Three necessary conditions or essentials of electromagnetic interference are: interference source, transmission channel and sensitive receiver. For customers, the solution of EMC problem is mainly in transmission channel because of the device attribute of disturbance source and receiver can not be changed.

### 4.6.2 EMC features of inverter

Like other electric or electronic devices, inverter is not only an electromagnetic interference source but also an electromagnetic receiver. The operating principle of inverter determines that it can produce certain electromagnetic interference noise. And the same time inverter should be designed with certain anti-jamming ability to ensure the

smooth working in certain electromagnetic environment. The following is its EMC features:

- Input current is non-sine wave. The input current includes large amount of high-harmonic waves that can cause electromagnetic interference, decrease the grid power factor and increase the line loss.
- Output voltage is high frequency PWM wave, which can increase the temperature rise and shorten the life of motor. And the leakage current will also increase, which can lead to the leakage protection device malfunction and generate strong electromagnetic interference to influence the reliability of other electric devices.
- As the electromagnetic receiver, too strong interference will damage the inverter and influence the normal using of customers.
- In the system, EMS and EMI of inverter coexist. Decrease the EMI of inverter can increase its EMS ability.

#### **4.6.3 EMC Installation Guideline**

In order to ensure all electric devices in the same system to work smoothly, this section, based on EMC features of inverter, introduces EMC installation process in several aspects of application (noise control, site wiring, grounding, leakage current and power supply filter). The good effective of EMC will depend on the good effective of all of these five aspects.

##### **4.6.3.1 Noise control**

All the connections to the control terminals must use shielded wire. And the shield layer of the wire must ground near the wire entrance of inverter. The ground mode is 360 degree annular connection formed by cable clips. It is strictly prohibitive to connect the twisted shielding layer to the ground of inverter, which greatly decreases or loses the shielding effect.

Connect inverter and motor with the shielded wire or the separated cable tray. One side of shield layer of shielded wire or metal cover of separated cable tray should connect to ground, and the other side should connect to the motor cover. Installing an EMC filter can reduce the electromagnetic noise greatly.

##### **4.6.3.2 Site wiring**

Power supply wiring: the power should be separated supplied from electrical transformer. Normally it is 5 core wires, three of which are fire wires, one of which is the neutral wire, and one of which is the ground wire. It is strictly prohibitive to use the same line to be both the neutral wire and the ground wire

Device categorization: there are different electric devices contained in one control cabinet, such as inverter, filter, PLC and instrument etc, which have different ability of emitting and withstanding electromagnetic noise. Therefore, it needs to categorize these devices into strong noise device and noise sensitive device. The same kinds of device should be placed in the same area, and the distance between devices of different category should be more than 20cm.

Wire Arrangement inside the control cabinet: there are signal wire (light current) and power cable (strong current) in one cabinet. For the inverter, the power cables are categorized into input cable and output cable. Signal wires can be easily disturbed by power cables to make the equipment malfunction. Therefore when wiring, signal cables and power cables should be arranged in different area. It is strictly prohibitive to arrange them in parallel or interlacement at a close distance (less than 20cm) or tie them together. If the signal wires have to cross the power cables, they should be arranged in 90 angles. Power input and output cables should not either be arranged in interlacement or tied together, especially when installed the EMC filter. Otherwise the distributed capacitances of its input and output power cable can be coupling each other to make the EMC filter out of function.

#### **4.6.3.3 Grounding**

Inverter must be ground safely when in operation. Grounding enjoys priority in all EMC methods because it does not only ensure the safety of equipment and persons, but also is the simplest, most effective and lowest cost solution for EMC problems.

Grounding has three categories: special pole grounding, common pole grounding and series-wound grounding. Different control system should use special pole grounding, and different devices in the same control system should use common pole grounding, and different devices connected by same power cable should use series-wound grounding.

#### **4.6.3.2 Leakage Current**

Leakage current includes line-to-line leakage current and over-ground leakage current. Its value depends on distributed capacitances and carrier frequency of inverter. The over-ground leakage current, which is the current passing through the common ground wire, can not only flow into inverter system but also other devices. It also can make leakage current circuit breaker, relay or other devices malfunction. The value of line-to-line leakage current, which means the leakage current passing through distributed capacitors of input output wire, depends on the carrier frequency of inverter, the length and section areas of motor cables. The higher carrier frequency of inverter,

the longer of the motor cable and/or the bigger cable section area, the larger leakage current will occur.

**Countermeasure:**

Decreasing the carrier frequency can effectively decrease the leakage current. In the case of motor cable is relatively long (longer than 50m), it is necessary to install AC reactor or sinusoidal wave filter at the output side, and when it is even longer, it is necessary to install one reactor at every certain distance.

**4.6.3.5 EMC Filter**

EMC filter has a great effect of electromagnetic decoupling, so it is preferred for customer to install it.

For inverter, noise filter has following categories:

- Noise filter installed at the input side of inverter;
- Install noise isolation for other equipment by means of isolation transformer or power filter.

**4.6.4 If user install inverter and EMI filter according to the installation guideline, we believe inverter system comply with following compliance.**

- EN61000-6-4
- EN61000-6-3
- EN61800-3



## 5. Operation

### 5.1 Operating keypad description

#### 5.1.1 Keypad schematic diagram

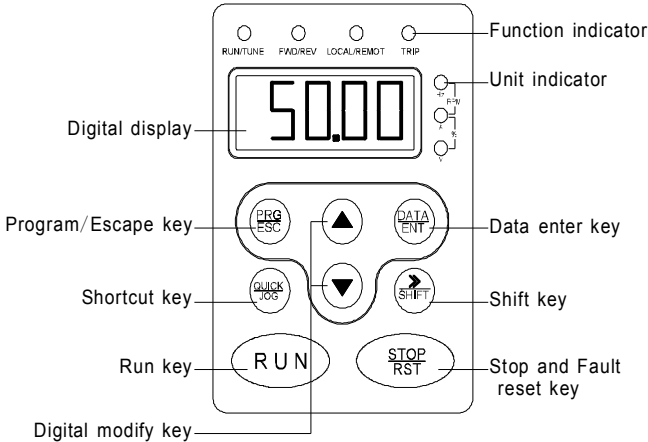





Figure 5.1 Keypad schematic diagram.

#### 5.1.2 Button function description

| Button | Name               | Description  |
|--------|--------------------|--|
|        | Programming Key    | Entry or escape of first-level menu.   |
|        | Enter Key          | Progressively enter menu and confirm parameters.   |
|        | UP Increment Key   | Progressively increase data or function codes.   |
|        | DOWN Decrement Key | Progressive decrease data or function codes.   |
|        | Shift Key          | In parameter setting mode, press this button to select the bit to be modified. In other modes, cyclically displays parameters by right shift |
|        | Run Key            | Start to run the inverter in keypad control mode.  |

| Button  | Name               | Description  |
|---|--------------------|--|
|    | STOP/RESET<br>Key  | In running state, restricted by P7.04, can be used to stop the inverter.<br>When fault alarm, can be used to reset the inverter without any restriction.   |
|    | Shortcut Key       | Determined by Function Code P7.03:<br>0: Jog operation<br>1: Switch between forward and reverse<br>2: Clear the <b>UP/DOWN</b> settings.<br>3: Quick debugging mode1 (by menu)<br>4: Quick debugging mode2 (by latest order)<br>5: Quick debugging mode3 (by non-factory setting parameters) |
| <br>+<br> | Combination<br>Key | Pressing the <b>RUN</b> and <b>STOP/RST</b> at the same time can achieve inverter coast to stop.   |

**5.1.3 Indicator light description**

5.1.3.1 Function indicator light description

| Function indicator | Description   |
|--------------------|---|
| <b>RUN/TUNE</b>    | Extinguished: stop state<br>Flickering: parameter autotuning state<br>Light on: operating state         |
| <b>FWD/REV</b>     | Extinguished: forward operation<br>Light on: reverse operation.   |
| <b>LOCAL/REMOT</b> | Extinguished: keypad control<br>Flickering: terminal control<br>Light on: communication control         |
| <b>TRIP</b>        | Extinguished: normal operation state<br>Flickering: overload pre-warning state<br>Light on: fault state |

## 5.1.3.2 Unit indicator light description

| Unit indicator | Description         |
|----------------|---------------------|
| Hz             | Frequency unit      |
| A              | Current unit        |
| V              | Voltage unit        |
| RPM            | Rotating speed unit |
| %              | Percentage          |
| Hz+V           | m/s                 |

## 5.1.3.3 Digital display

Have 5 digit LED , which can display all kinds of monitoring data and alarm codes such as reference frequency, output frequency and so on.

## 5.2 Operation process

### 5.2.1 Parameter setting

Three levels of menu are:

- Function code group (first- class);
- Function code (second- class);
- Function code value (third- class).

Remarks:

Pressing both the **PRG/ESC** and the **DATA/ENT** can return to the second-class menu from the third-class menu. The difference is: pressing **DATA/ENT** will save the set parameters into the control panel, and then return to the second-class menu with shifting to the next function code automatically; while pressing **PRG/ESC** will directly return to the second-class menu without saving the parameters, and keep staying at the current function code.

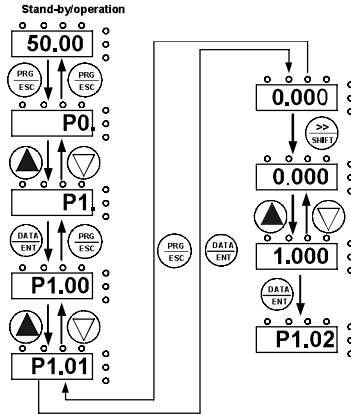

Figure 5.2 Flow chart of parameter setting.

Under the third-class menu, if the parameter has no flickering bit, it means the function code cannot be modified. The possible reasons could be:

- This function code is not modifiable parameter, such as actual detected parameter, operation records and so on;
- This function code is not modifiable running state, but modifiable in stop state.

### 5.2.2 Fault reset

If the inverter has fault, it will prompt the related fault information. User can use **STOP/RST** or according terminals determined by P5 Group to reset the fault. After fault reset, the inverter is at stand-by state. If user does not reset the inverter when it is at fault state, the inverter will be at operation protection state, and can not run.

### 5.2.3 Parameter copy

For details, please refer to the instructions of LCD keypad functions

### 5.2.4 Motor parameter autotune

If "Sensorless Vector Control" or "Vector Control with PG" mode is chosen, motor nameplate parameters must be input correctly as the autotuning is based on it. The performance of vector control depends on the parameters of motor strongly, so to achieve excellent performance, firstly must obtain the parameter of motor exactly.

This function is not the same between synchronous motor and asynchronous motor, for details please refer to the description of function code P0.08.

The procedure of motor parameter autotuning is as follows:

Firstly, choose keypad command as the run command source (P0.01).

Set P0.17 to be 1, and for the detail process of motor parameter autotuning, please refer

to the description of Function Code P0.17. And then press **RUN** on the keypad panel, the inverter will automatically calculate parameters of the motor.

Then motor autotuning is finished.

In the self-learning process, use **>/SHIFT** can change parameters and monitor running state of inverter.

**Note: the motor should be uncoupled with its load; otherwise, the motor parameters obtained by autotuning may be not correct.**

### 5.2.5 Password setting

CHV180 series inverter offers user's password protection function. When P7.00 is set to be nonzero, it will be the user's password, and after exiting function code edit mode, it will become effective instantly. If pressing the **PRG/ESC** again to try to access the function code edit mode, "----" will be displayed, and the operator must input correct user's password, otherwise will be unable to access it.

If it is necessary to cancel the password protection function, just set P7.00 to be zero.

**Note: Password is not effective for parameters in shortcut menu.**

## 5.3 Running state

### 5.3.1 Power-on initialization



Firstly the system initializes during the inverter power-on, and LED displays "8.8.8.8.8". After the initialization is completed, the inverter is on stand-by state.

### 5.3.2 Stand-by



At stop or running state, parameters of multi-state can be displayed. Whether or not to display this parameter can be chosen through Function Code P7.06 (Running state display selection) and P7.07 (Stop state display selection) according to binary bits, the detailed description of each bit please refers the function code description of P7.06 and P7.07.

In stop state, there are 16 parameters which can be chosen to display or not. They are: reference speed, reference frequency, DC bus voltage, Input-Output terminal state, open collector output state, PID setting, PID feedback, AI1 voltage, AI2 voltage, AI3 voltage/current, AI4 voltage, HDI1 frequency, HDI2 frequency, step number of simple PLC or multi-step speed, length value. Whether or not to display can be determined by setting the corresponding binary bit of P7.07. Press the **▶/SHIFT** to scroll through the parameters in right order. Press **DATA/ENT** + **QUICK/JOG** to scroll through the parameters in left order.

### 5.3.3 Operation

In running state, there are twenty one running parameters which can be chosen to display or not. They are: running frequency, reference frequency, DC bus voltage, output voltage, output current, rotating speed, output power, output torque, PID setting, PID feedback, ON-OFF input state, open collector output state, length value, count value, step number of PLC or multi-step speed, AI1 voltage, AI2 voltage, AI3 voltage/current, AI4 voltage, HDI1 frequency, HDI2 frequency. Whether or not to display can be determined by setting the corresponding binary bit of P7.06. Press the  /SHIFT to scroll through the parameters in right order . Press  +  to scroll through the parameters in left order.

### 5.3.4 Fault

In fault state, the inverter will display parameters of STOP state besides parameters of fault state. Press the  /SHIFT to scroll through the parameters in right order . Press  +  to scroll through the parameters in left order.

CHV180 serials inverter provides much information when fault occur. Please refer to chapter 8 for more detailed information.

## 6. Detailed function description

### 6.1 P0 Group--Basic function

| Function Code | Name               | Description   | Setting Range | Factory Setting |
|---------------|--------------------|---|---------------|-----------------|
| P0.00         | Speed control mode | 0: Sensorless vector control<br>1: Vector control With PG<br>2: V/F control | 0~2           | 1               |

0: Sensorless vector control: It is widely used in the application such as low-grade elevator which requires lower accuracy or used for debugging.

1: Vector control with PG: Close-loop vector control requires the client to install the speed feedback equipment. Therefore it is suitable for the high-grade elevator requiring high speed control accuracy and speedy dynamic response.

2: V/F control: It is suitable for the low-end elevator which requires lower accuracy or is used for debugging.

#### Note:

When selecting the vector control, it is necessary to set the nameplate parameters and encoder parameters correctly and complete the autotuning before running to get right motor parameters (for synchronous motor, it is the pole position angle). Right parameters are the assurance for high performance of vector control.

P3 group can optimize the performance of vector control.

| Function Code | Name               | Description  | Setting Range | Factory Setting |
|---------------|--------------------|--|---------------|-----------------|
| P0.01         | Run command source | 0: Keypad (LED extinguished)<br>1: Terminal (LED flickering)<br>2: Communication (LED lights on) | 0~2           | 1               |

The control commands of inverter include: start, stop, up, down, fault reset and so on.

0: Keypad ("LOCAL/REMOT" LED extinguished);

Both **RUN** and **STOP/RST** key are used for running command control. If Multifunction key **QUICK/JOG** is set as FWD/REV switching function (P7.03 is set to be 1), it will be used to change the rotating orientation. **In running state, pressing **RUN** and **STOP/RST** in the same time will cause the inverter coast to stop.**

1: Terminal ("LOCAL/REMOT" LED flickering)

The operation, including up, down etc. can be controlled by multifunctional input terminals.

2: Communication (“LOCAL/REMOT” LED lights on)

The operation of inverter can be controlled by host through communication. If select “Communication”, the user should select the serial communication extension card which matches with CHV180 serials inverter.

| Function Code | Name                 | Description | Setting Range | Factory Setting |
|---------------|----------------------|-------------|---------------|-----------------|
| P0.02         | Elevator rated speed | 0.100~4.000 | 1.500m/s      | 1               |

P0.02 is the rated speed on the elevator nameplate; the setting value should be less than the elevator rated speed. The relationship of the inverter’s output frequency and the elevator’s running line speed is linear. The expression is as follow:

$$f = \frac{60ikf_N}{3.14Dn_N} v$$

*f* represents output frequency of elevator, *v* represents running linear speed of the elevator, *D* represents diameter of tractor (P2.01), *i* represents reduction ratio(P2.02), *k* represents hoist hanging ratio(P2.03), *f<sub>N</sub>* represents rated frequency of motor (P2.05), *n<sub>N</sub>* represents rated rotational speed of motor (P2.06).

**Note: The speed of elevator is limited by P0.02, and the maximum output frequency of inverter is limited by P0.04, so the maximum running line speed of elevator is limited by both P0.02 and P0.04.**

| Function Code | Name                 | Description   | Setting Range | Factory Setting |
|---------------|----------------------|---|---------------|-----------------|
| P0.03         | Speed command source | 0: Keypad<br>1: AI1<br>2: AI2<br>3. Multi-Step speed<br>4. Communication<br>5. AI1 tracking running | 0~5           | 3               |

0: Keypad

Please refer to description of P0.05.

1: AI1

2: AI2

The reference speed is set by analog input. AI1 is 0~10V voltage input terminal, while AI2 is 0~10V voltage input or 0(4)~20mA current input. The switching between voltage



input and current input is controlled by the jumper wire J18.

**Note:**

**100% of AI is corresponding to the rated speed of the elevator.**

3: Multi-step speed

The reference frequency is determined by P1 group and P5 group. The selection of steps is determined by combination of multi-step speed terminals.

**Note:**

- **Multi-step speed mode will enjoy priority in setting reference frequency if P0.03 is not set to be 3. In this case, only step 1 to step 7 are available.**
- **If P0.03 is set to be 3, step 0 to step 7 can be realized.**

4: Communication

The reference frequency is set through RS485. For details, please refer to chapter 11.

5: AI1 tracking running

Running s-curve when is decided by external controller, and internal acceleration and deceleration is invalid.

**Note:**

- **When P0.03 is set to be 5, the process of acceleration and deceleration is decided by external controller, the inverter tracks the change process of analog automatically. P0.03 is set to be 1 or 2, the process of acceleration and deceleration is decided by internal controller.**
- **Speed command and analog weighing signal input can't select the same analog input channel.**

| Function Code | Name              | Description | Setting Range | Factory Setting |
|---------------|-------------------|-------------|---------------|-----------------|
| P0.04         | Maximum frequency | 10~400.00Hz | 10.0~400.00   | 50.00Hz         |

**Note:**

- **The frequency reference should not exceed maximum frequency.**
- **Actual acceleration time and deceleration time are determined by maximum frequency.**

| Function Code | Name                   | Description  | Setting Range | Factory Setting |
|---------------|------------------------|--------------|---------------|-----------------|
| P0.05         | Keypad reference speed | 0.00 ~ P0.02 | 1.500m/s      | 1.500m/s        |

When P0.03 is set to be 0, this parameter is the reference speed of the inverter.

| Function Code | Name                        | Description   | Setting Range | Factory Setting |
|---------------|-----------------------------|---|---------------|-----------------|
| P0.06         | Running direction selection | 0: Default direction<br>1: Reverse<br>2: Forbid reverse | 0~2           | 0               |

**Note:**

0: Run at the default direction. After powering on, the inverter will run at the default direction.

1: Run at the reverse direction. Changing the function code can change the running direction of the motor. The result is the same as that of adjusting the motor wires (U, V and W).

**Note: After the parameter initialization, the running direction will restore to the original one. It is prohibited to change the direction after commissioning.**

2: Reverse running prohibition. It is prohibited to run at the reverse direction in some special situation.

| Function Code | Name              | Description | Setting Range | Factory Setting |
|---------------|-------------------|-------------|---------------|-----------------|
| P0.07         | Carrier frequency | 1.0~16.0kHz | 1.0~16.0      | Depend on model |

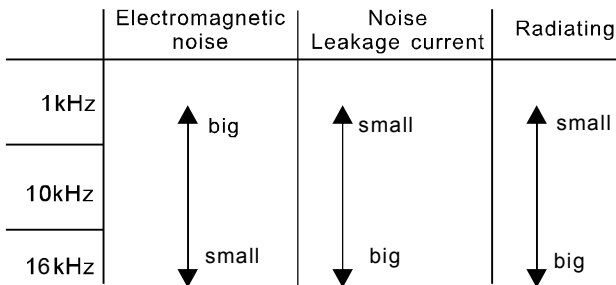

Figure 6.1 Effect of carrier frequency

| Model | Carrier frequency | Factory Setting( kHz ) |
|-------|-------------------|------------------------|
|       | 4kW~11kW          | 8                      |
|       | 15kW~30kW         | 4                      |

The advantage of high carrier frequency: ideal current waveform, little current harmonic wave and motor noise.

The disadvantage of high carrier frequency: increasing the switch loss, increasing inverter temperature and the impact to the output capacity. The inverter needs to derate on high carrier frequency. At the same time, the leakage and electrical magnetic interference will increase.

Applying low carrier frequency is contrary to the above, too low carrier frequency will cause unstable running, torque decreasing and surge.

The manufacturer has set a reasonable carrier frequency when the inverter is in factory. In general, users do not need to change the parameter.

When the frequency used exceeds the default carrier frequency, the inverter needs to derate 20% for each additional 1k carrier frequency.

| Function Code | Name                        | Description  | Setting Range | Factory Setting |
|---------------|-----------------------------|--|---------------|-----------------|
| P0.08         | Motor parameters autotuning | 0: No action<br>1: Rotation autotuning<br>2: Static autotuning | 0~2           | 0               |

0: No action, forbid autotuning.

1: Rotation autotuning:

Do not connect any load to the motor when performing autotuning and ensure the motor is in static state.

Input the nameplate parameters of motor (P2.04~P2.08) correctly before performing autotuning. Otherwise the parameters detected by autotuning will be incorrect; it may influence the performance of inverter.

The operation process is as follow:

- Set P0.08 to be 1 then press the **DATA/ENT**, LED will display “-TUN-” and flickers. During “-TUN-” is flickering, press the **PRG/ESC** to exit autotuning.
- Press the **RUN** to start the autotuning. LED will display “TUN-0”.
- After a few seconds the motor will start to run. LED will display “TUN-1” and “RUN/TUNE” light will flicker.
- After a few minutes, LED will display “-END-”. That means the autotuning is finished

and return to the stop state.

e. During the autotuning, press the **>>/SHIFT**, it can switch keypad to display parameters, and monitor the running state. Press the **STOP/RS1**, the autotuning will stop .

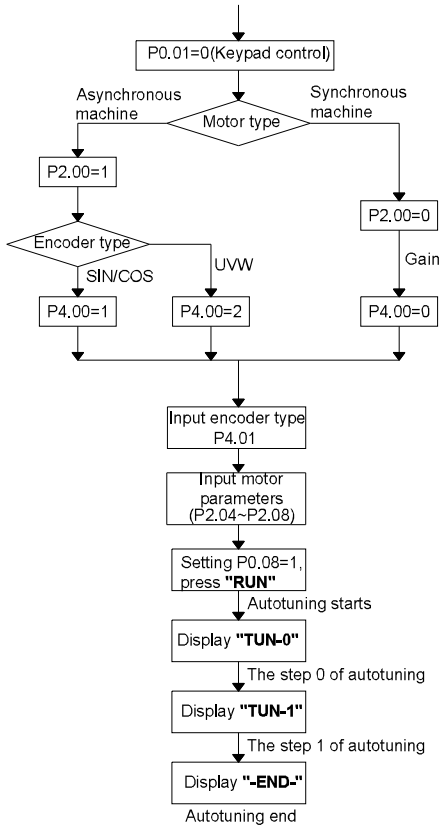

**Note: If it reports fault of PCDE in the process of autotuning, please modify**

The direction of encoder. Please check the wiring of encoder when there are other faults related to encoder.

Autotuning of synchronous motor's result is the parameters (P4.03 and P4.07~P4.09) related magnetic pole. Autotuning of asynchronous motor's result is the parameters (P2.10~P2.14).

2: Static autotuning:

When performing static autotuning, If it is difficult to disconnect the load, static autotuning is recommended, and choose the right motor style, input parameters (P2.04~P2.08) on the nameplate of motor. For asynchronous motor, the stator resistor, rotor resistor,

leakage inductance of motor can be detected and the mutual inductance and current without load will not be detected by static autotuning.If needed, user should input suitable value according to experience.

For synchronous motor, the self-learning current (P4.10) is set to get the magnetic pole initial position (P4.03).

**Note:**

- **Correct the zero-bias value of encoder (P4.08 and P4.09) which is displayed by Pb.06 and Pb.07 when it is not connected to the encoder.**
- **The direction of encoder (P4.02) must be right.When the inverter is forwarding, the motor is counterclockwise rotation seen from motor shaft side, and the direction of encoder is set to be forward.**
- **When autotuning, the actual current (Pb.03) should be between 80.0% and 110%, or adjust P4.10.**
- **Continuous autotuning for 3 times, if the deviation of each magnetic pole position is less than 10 degrees, it shows the autotuning is right, otherwise if the magnetic pole is more than 10 degrees, it must be reautotuned.**
- **Static autotuning is valid for SIN/COS encoder, and rotation autotuning is suitable for UVW encoder.**

| Function Code | Name               | Description  | Setting Range | Factory Setting |
|---------------|--------------------|--|---------------|-----------------|
| P0.09         | Restore parameters | 0: No action<br>1: Restore factory setting<br>2: Clear fault records | 0~2           | 0               |
| P0.10         | Reserved           | Reserve  | 0~65535       | 0               |
| P0.11         | Reserved           | Reserve  | 0~65535       | 0               |

**6.2 P1 Group--Speed curve**

| Function Code | Name               | Description | Setting Range | Factory Setting |
|---------------|--------------------|-------------|---------------|-----------------|
| P1.00         | Multi-step speed 0 | 0.000~P0.02 | 0.000~P0.02   | 0.000m/s        |
| P1.01         | Multi-step speed 1 | 0.000~P0.02 | 0.000~P0.02   | 0.000m/s        |
| P1.02         | Multi-step speed 2 | 0.000~P0.02 | 0.000~P0.02   | 0.000m/s        |

| Function Code | Name               | Description | Setting Range | Factory Setting |
|---------------|--------------------|-------------|---------------|-----------------|
| P1.03         | Multi-step speed 3 | 0.000~P0.02 | 0.000~P0.02   | 0.000m/s        |
| P1.04         | Multi-step speed 4 | 0.000~P0.02 | 0.000~P0.02   | 0.000m/s        |
| P1.05         | Multi-step speed 5 | 0.000~P0.02 | 0.000~P0.02   | 0.000m/s        |
| P1.06         | Multi-step speed 6 | 0.000~P0.02 | 0.000~P0.02   | 0.000m/s        |
| P1.07         | Multi-step speed 7 | 0.000~P0.02 | 0.000~P0.02   | 0.000m/s        |

Multi-step speed is defined by P1.00~P1.07. The 8-step speed will be come true by the combination of 3 multi-step speed terminals. The detailed description is as follow:

| Multi-step speed terminal 3 | Multi-step speed terminal 2 | Multi-step speed terminal 1 | Speed Setting      | Function code |
|-----------------------------|-----------------------------|-----------------------------|--------------------|---------------|
| OFF                         | OFF                         | OFF                         | Multi-step speed 0 | P1.00         |
| OFF                         | OFF                         | ON                          | Multi-step speed 1 | P1.01         |
| OFF                         | ON                          | OFF                         | Multi-step speed 2 | P1.02         |
| OFF                         | ON                          | ON                          | Multi-step speed 3 | P1.03         |
| ON                          | OFF                         | OFF                         | Multi-step speed 4 | P1.04         |
| ON                          | OFF                         | ON                          | Multi-step speed 5 | P1.05         |
| ON                          | ON                          | OFF                         | Multi-step speed 6 | P1.06         |
| ON                          | ON                          | ON                          | Multi-step speed 7 | P1.07         |

| Function Code | Name                            | Description  | Setting Range | Factory Setting       |
|---------------|---------------------------------|--------------|---------------|-----------------------|
| P1.08         | Start quadric acceleration      | 0.001~10.000 | 0.001~10.000  | 0.350m/s <sup>3</sup> |
| P1.09         | Start acceleration              | 0.001~10.000 | 0.001~10.000  | 0.700m/s <sup>2</sup> |
| P1.10         | Speed-down quadric deceleration | 0.001~10.000 | 0.001~10.000  | 0.350m/s <sup>3</sup> |

| Function Code | Name                      | Description  | Setting Range | Factory Setting       |
|---------------|---------------------------|--------------|---------------|-----------------------|
| P1.11         | Deceleration              | 0.001~10.000 | 0.001~10.000  | 0.700m/s <sup>2</sup> |
| P1.12         | Stop quadric deceleration | 0.001~10.000 | 0.001~10.000  | 0.350m/s <sup>3</sup> |
| P1.13         | Stop deceleration         | 0.001~10.000 | 0.001~10.000  | 0.700m/s <sup>2</sup> |
| P1.14         | Start speed               | 0.000~0.250  | 0.000~0.250   | 0.000m/s              |
| P1.15         | Start holding time        | 0.0~5.0s     | 0.0~5.0s      | 0.0s                  |

The sharp of S-curve was decided by P1.08~P1.13, the quality of S-curve can directly affect the comfortable feeling of elevator's start and stop. The parameters of S-curve were comprised of start quadric acceleration (P1.08), start acceleration (P1.09), speed-down quadric deceleration (P1.10), deceleration (P1.11), stop quadric deceleration (P1.12), stop deceleration (P1.13), start speed (P1.14) and start holding time (P1.15). The correspondence relation of the parameters and S-curve is as follow:

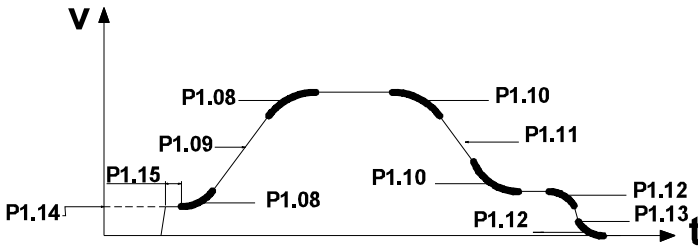

Figure 6.3 S - curve running diagram.

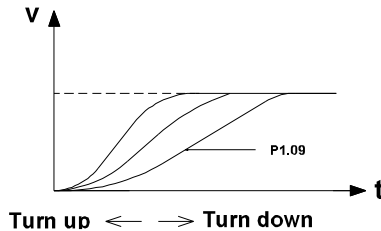

Figure 6.4 S - curve setting sketch map description.

The above diagram is the sketch map of setting s-curve of accelerated portion, the s-curve steepens as the parameter was increased, and the s-curve slackens as the parameter was decreased. S-curve adjustment principle of deceleration segment and stop segment is the same with principle of acceleration.

P1.14 is the initial speed when the inverter starts. If the setting speed is less than start speed, the output frequency is 0 when running. Only when the setting speed is greater than or equal to start speed, the inverter will start with start speed, and run according to S-curve. If setting a right value, overcome static friction, and reduce shock at starting.

P1.15 is the duration time with starting speed in the process of starting.

**Note: P1.08, P1.10 and P1.12 are key parameters of s-curve, and this parameter can influence the passengers' comfortable feeling during acceleration, deceleration and stopping respectively, so please adjust them carefully**

| Function Code | Name                          | Description  | Setting Range | Factory Setting       |
|---------------|-------------------------------|--------------|---------------|-----------------------|
| P1.16         | Overhaul running speed        | 0.000~P0.02  | 0.000~P0.02   | 0.300m/s              |
| P1.17         | Overhaul running acceleration | 0.001~10.000 | 0.001~10.000  | 1.000m/s <sup>2</sup> |
| P1.18         | Overhaul running deceleration | 0.001~10.000 | 0.001~10.000  | 1.000m/s <sup>2</sup> |

These parameters are used to set overhaul running speed, acceleration and deceleration. The overhaul running curve is as follow:

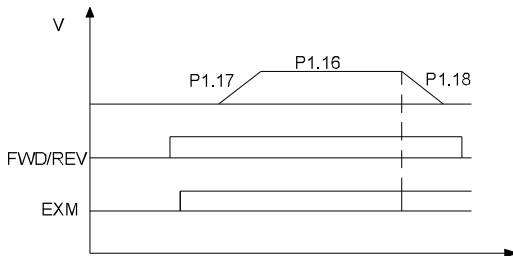

Figure 6.5 Overhaul running curve.

Please refer to chapter 8.2.2 for detailed curve and sequence diagram.

**Note: The priority of speed selection is that: forced deceleration > emergency running > overhaul running > multi-step speed running > keypad setting, analog setting or communication setting.**



| Function Code | Name                          | Description  | Setting Range | Factory Setting        |
|---------------|-------------------------------|--------------|---------------|------------------------|
| P1.19         | Motor autotuning acceleration | 0.001~10.000 | 0.001~10.000  | 0.600 m/s <sup>2</sup> |
| P1.20         | Motor autotuning deceleration | 0.001~10.000 | 0.001~10.000  | 0.600m/s <sup>2</sup>  |

These parameters are used to set acceleration and deceleration of motor's parameter autotuning.

| Function Code | Name  | Description  | Setting Range | Factory Setting       |
|---------------|---|--------------|---------------|-----------------------|
| P1.21         | Emergency running speed                     | 0.000~P0.02  | 0.000~P0.02   | 0.300m/s              |
| P1.22         | Emergency running acceleration/deceleration | 0.001~10.000 | 0.001~10.000  | 1.000m/s <sup>2</sup> |

These parameters are used to set the emergency running speed, acceleration and deceleration of emergency running.

- The description of emergency running is as follow: at the time of power-off, the control system accesses the accumulator into (+) and (-) terminals with bypass switch. The inverter receives the command of emergency running speed and running direction from controller and the elevator will stop to the closer aiming storey automatically.
- The wiring of emergency running:

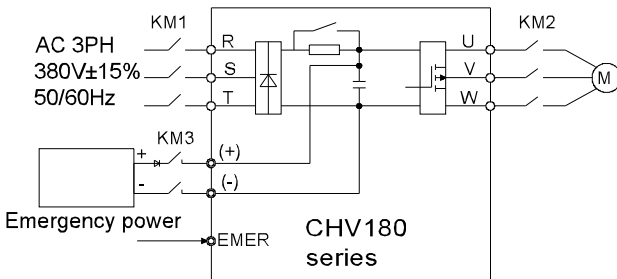

Figure 6.6 The wiring of emergency running.

- The curve and sequence diagram of emergency running:

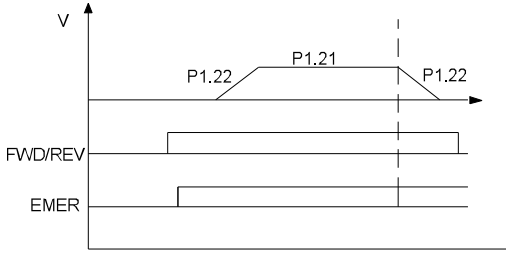

Figure 6.7 The emergency running curve.

Please refer to chapter 8.2.3 for detailed emergency running.

**Note: if use the function of emergency running, need shield the inverter protection function of input open-phase (P9.00=0).**

**The emergency voltage is requested to be greater than DC 250V.**

| Function Code | Name                                  | Description  | Setting Range | Factory Setting         |
|---------------|---------------------------------------|--------------|---------------|-------------------------|
| P1.23         | Forced deceleration speed 1           | P1.25~10.000 | P1.25~10.000  | 1.000m/s <sup>2</sup>   |
| P1.24         | Forced deceleration speed 1 detection | 0.0~P1.26    | 0.0~P1.26     | 20.0%                   |
| P1.25         | Forced deceleration speed 2           | P1.27~P1.23  | P1.27~P1.23   | 0.900m/s <sup>2</sup>   |
| P1.26         | Forced deceleration speed 2 detection | P1.24~P1.28  | P1.24~P1.28   | 40.0%                   |
| P1.27         | Forced deceleration speed 3           | 0.001~P1.25  | 0.001~P1.25   | 0.700m/sP <sup>2P</sup> |
| P1.28         | Forced deceleration speed 3           | P1.26~100.0% | P1.26~100.0%  | 80.0%                   |

| Function Code | Name      | Description | Setting Range | Factory Setting |
|---------------|-----------|-------------|---------------|-----------------|
|               | detection |             |               |                 |

The above function codes will be valid after the forced deceleration switch input is selected, the effect of forced deceleration is to prevent elevator from top-hitting or bottom-clashing in the process of up or down running. There is only one group forced deceleration switch in low speed elevator, and there are two or three groups forced deceleration switches in the high speed elevator. The installation of sketch map is as figure 6.8:

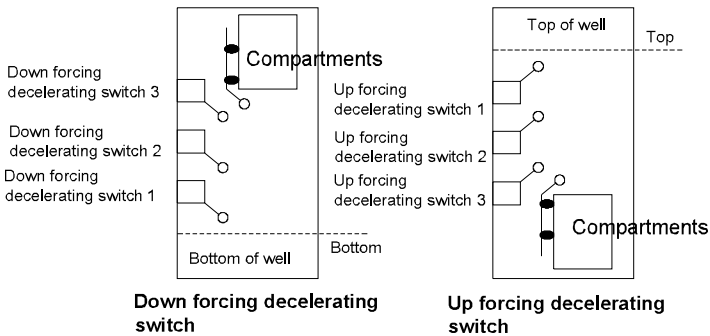

Figure 6.8 Installation sketch of forced deceleration switch.

For example, when the elevator is running up close to top, forced deceleration switch 3 will act, if the checked running speed is greater than  $P1.28 \times P0.02$  at this time, elevator will decelerate at the value of  $P1.27$  to 0, The detailed curve is as follow:

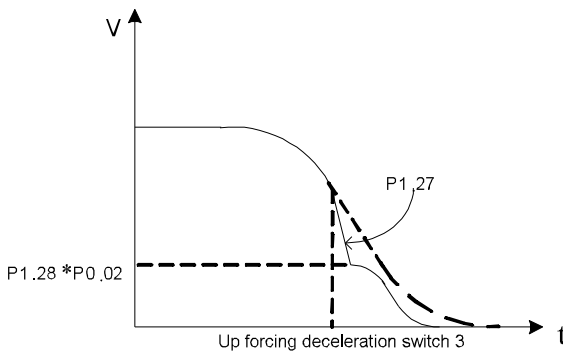

Figure 6.9 Forced deceleration running chart.

Forcing deceleration running conditions:

- Feedback terminals signal of forced deceleration switch action is effective.
- During run-up process, it comes across up-forcing switch, or during run-down process, it comes across down-forcing switch.
- Current running speed is greater than the detected speed of corresponding forced deceleration switch, if not; the inverter will keep the current running state.
- After the forcing decelerating action, the speed will be reduced continuously with P1.23, P1.25, and P1.27 until 0.

**Note:**

**1)The priority of forced deceleration is only less than the priority of forcing slow-down to stop, the priority is like this: forced deceleration 1 > forced deceleration 2 > forced deceleration 3.**

**2) The 100% of forced deceleration detection value is corresponding with elevator rated speed (P0.02).**

**3) It will not response the forced deceleration during motor autotuning.**

| Function Code | Name                | Description                               | Setting Range | Factory Setting |
|---------------|---------------------|---|---------------|-----------------|
| P1.29         | Stop mode selection | 0: Decelerate to stop<br>1: Coast to stop | 0~1           | 1               |

0: Decelerate to stop

When the stop command takes effect, the inverter decreases the output frequency according to stop deceleration and stop quadric deceleration till stops.

1: Coast to stop

When the stop command takes effect, the inverter stops the output immediately. The motor coasts to stop by its mechanical inertia.

| Function Code | Name     | Description | Setting Range | Factory Setting |
|---------------|----------|-------------|---------------|-----------------|
| P1.30         | Reserved | 0~65536     | 0~65536       | 0               |
| P1.31         | Reserved | 0~65536     | 0~65536       | 0               |

**6.3 P2 Group--Motor parameters**

| Function Code | Name        | Description                                   | Setting Range | Factory Setting |
|---------------|-------------|---|---------------|-----------------|
| P2.00         | Motor model | 0: Asynchronous motor<br>1: Synchronous motor | 0~1           | 1               |

**Note: Select right model of motor before performing parameters autotuning.**

| Function Code | Name                             | Description | Setting Range | Factory Setting |
|---------------|----------------------------------|-------------|---------------|-----------------|
| P2.01         | Wheel diameter of traction motor | 100~2000    | 100~2000      | 500mm           |
| P2.02         | Reduction ratio                  | 1.00~100.00 | 1.00~100.00   | 30.00           |
| P2.03         | Hoist rope hanging ratio         | 1~8         | 1~8           | 1               |

P2.01, P2.02 and P2.03 are parameters of the elevator traction motor, only when parameters are set correctly, the inverter running-speed can be right parallelism with elevator's factual speed. Please refer to P0.02.

| Function Code | Name                  | Description  | Setting Range | Factory Setting |
|---------------|-----------------------|--------------|---------------|-----------------|
| P2.04         | Motor rated power     | 0.4~900.0kW  | 0.4~900.0     | Depend on model |
| P2.05         | Motor rated frequency | 0.01Hz~P0.04 | 0.01~P0.04    | 50.00Hz         |
| P2.06         | Motor rated speed     | 1~36000rpm   | 1~36000       | 1460rpm         |
| P2.07         | Motor rated voltage   | 1~460V       | 1~460         | 380V            |
| P2.08         | Motor rated current   | 0.1~1000.0A  | 0.1~1000.0    | Depend on model |

**Note:**

- In order to achieve superior performance, please set these parameters according to motor nameplate, and then perform autotuning.
- The rated power of inverter should match the motors. If the gap is too big, the control performances of inverter will be deteriorated distinctly.
- Resetting P2.04 can initialize P2.10~P2.14.

| Function Code | Name                     | Description | Setting Range | Factory Setting |
|---------------|--------------------------|-------------|---------------|-----------------|
| P2.09         | Motor rated power factor | 0.05~1.00   | 0.05~1.00     | 0.86            |

When the inverter cannot perform autotuning, it may optimize motor control performance by setting the motor rated power factor.

| Function Code | Name                        | Description   | Setting Range | Factory Setting |
|---------------|-----------------------------|---------------|---------------|-----------------|
| P2.10         | Motor stator resistor       | 0.001~65.535Ω | 0.001~65.535  | Depend on model |
| P2.11         | Motor rotor resistor        | 0.001~65.535Ω | 0.001~65.535  | Depend on model |
| P2.12         | Stator and rotor inductance | 0.1~6553.5mH  | 0.1~6553.5    | Depend on model |
| P2.13         | Motor mutual inductance     | 0.1~6553.5mH  | 0.1~6553.5    | Depend on model |
| P2.14         | Motor current without load  | 0.01~655.35A  | 0.01~655.35   | Depend on model |

After autotuning, the value of P2.10~P2.14 will be automatically updated.

**Note: Do not change these parameters; otherwise it may deteriorate the control performance of the inverter.**

| Function Code | Name     | Description | Setting Range | Factory Setting |
|---------------|----------|-------------|---------------|-----------------|
| P2.15         | Reserved | 0~65536     | 0~65536       | 0               |
| P2.16         | Reserved | 0~65536     | 0~65536       | 0               |

## 6.4 P3 Group--Vector control

| Function Code | Name                                     | Description | Setting Range | Factory Setting |
|---------------|--|-------------|---------------|-----------------|
| P3.00         | ASR low speed proportion gain            | 0~100       | 0~100         | 20              |
| P3.01         | ASR low speed integral time              | 0.01~10.00s | 0.01~10.00    | 0.50s           |
| P3.02         | Speed detection low speed filtrate times | 0~9         | 0~9           | 3               |

| Function Code | Name                                      | Description  | Setting Range | Factory Setting |
|---------------|---|--------------|---------------|-----------------|
| P3.03         | Switch low point frequency                | 0.00Hz~P3.07 | 0.00~P3.07    | 5.00Hz          |
| P3.04         | ASR high speed proportion gain            | 0~100        | 0~100         | 25              |
| P3.05         | ASR high speed integral time              | 0.01~10.00s  | 0.01~10.00s   | 1.00s           |
| P3.06         | Speed detection high speed filtrate times | 0~9          | 0~9           | 3               |
| P3.07         | Switch high point frequency               | P3.03~P0.04  | P3.03~P0.04   | 10.00Hz         |

The above parameters are only valid for vector control. When under the low point switch frequency (P3.03), speed loop parameter PI is P3.00 and P3.01, when over the high low point switch frequency (P3.07), speed loop parameter PI is P3.04 and P3.05. Please refer to following figure for details.

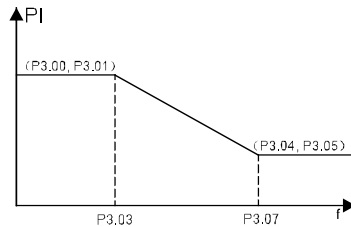

Figure 6.10 PI parameter diagram.

The system's dynamic response can be faster if the proportion gain  $K_p$  is increased or the integral time  $K_i$  is decreased; however, if  $K_p$  is too large or  $K_i$  is too small, the system becomes overshoot and tends to oscillate. If  $K_p$  is too small, may cause the system

steady-state-oscillation, and maybe the speed static will occur.

Speed loop parameter PI has strong relationship with the system's inertia, in order to meet the requirement of any situation; the PI should be adjusted based on the default set when the load of the system changed.

P3.02 and P3.06 are filter times of motor speed detection which need not to be adjusted, increase the values if there is current noise when motor is running.

| Function Code | Name                    | Description | Setting Range | Factory Setting |
|---------------|-------------------------|-------------|---------------|-----------------|
| P3.08         | ACR proportional gain P | 0~65535     | 0~65535       | 1600            |
| P3.09         | ACR integral gain I     | 0~65535     | 0~65535       | 300             |

**Note: The above parameters are related to the ACR adjustment, which directly affects the dynamic response and control accuracy if the system. Generally, the user can not modify the value.**

| Function Code | Name                                 | Description | Setting Range | Factory Setting |
|---------------|--------------------------------------|-------------|---------------|-----------------|
| P3.10         | Slip compensation rate of drive side | 50.0~200.0% | 50~200        | 100%            |
| P3.11         | Slip compensation rate of trig side  | 50.0~200.0% | 50~200        | 100%            |

The parameter is used to adjust the slip frequency of vector control and improve the precision of speed control. Properly adjusting this parameter can effectively restrain the steady-state error.

CHV180 series inverter can set electromotion state and regenerate brake state separately; P3.10 is suitable for electromotion state. P3.11 is suitable for regenerate feedback state.

| Function Code | Name         | Description | Setting Range | Factory Setting |
|---------------|--------------|-------------|---------------|-----------------|
| P3.12         | Torque upper | 0.0~200.0%  | 0.0~200.0     | 150.0%          |



| Function Code | Name  | Description | Setting Range | Factory Setting |
|---------------|-------|-------------|---------------|-----------------|
|               | limit |             |               |                 |

100.0% corresponds with the rated current of inverter.

| Function Code | Name     | Description | Setting Range | Factory Setting |
|---------------|----------|-------------|---------------|-----------------|
| P3.13         | Reserved | 0~65536     | 0~65536       | 0               |
| P3.14         | Reserved | 0~65536     | 0~65536       | 0               |

## 6.5 P4 Group -- Encoder parameter

| Function Code | Name                   | Description | Setting Range | Factory Setting |
|---------------|------------------------|-------------|---------------|-----------------|
| P4.00         | Encoder type selection | 0~2         | 0~2           | 1               |

When selecting the type of encoder, asynchronous motor and synchronous motor need different PG cards, please refer to chapter 7.3 and 7.4 for wiring of encoder.

0: Increment encoder

1: SIN/COS encoder

The matching model is ERN1387, or the encoder is compatible with it's' signal.

2: UVM encoder

The pole number of encoder must be the same with that of the motor.

**Note: When P2.00=0 (asynchronous motor), only the increment encoder can be chosen; when P2.01=1 (synchronous motor), only the SIN/COS and UVM encoder can be chosen.**

| Function Code | Name                   | Description | Setting Range | Factory Setting |
|---------------|------------------------|-------------|---------------|-----------------|
| P4.01         | PG pulse number        | 1~65536     | 1~65536       | 1000            |
| P4.02         | PG direction selection | 0~1         | 0~1           | 0               |

P4.01: Setting the number of encoder pulse per cycle.

**Note: When P0.00 is set to be 1, P4.10 must be set correctly according to the encoder parameter, otherwise the motor will run abnormally. If the motor still run abnormally when P4.10 has been set correctly, please change the PG direction (P4.02). The autotuning should be performed again for synchronous motor**

when P4.02 is changed.

| Function Code | Name                           | Description | Setting Range | Factory Setting |
|---------------|--------------------------------|-------------|---------------|-----------------|
| P4.03         | Magnetic pole initial position | 0.00~360.00 | 0.00~360.00   | 0.00            |

Magnetic pole initial position will be updated automatically after autotuning of synchronous motor, the parameter shouldn't be modified.

**Note: For the magnetic pole initial position, its corresponding angle is electric angle.**

| Function Code | Name  | Description | Setting Range | Factory Setting |
|---------------|---|-------------|---------------|-----------------|
| P4.04         | Thread break detection time of encoder low speed  | 0.0~100.0s  | 0.0~100.0     | 1.0             |
| P4.05         | Thread break detection time of encoder high speed | 0.0~100.0s  | 0.0~100.0     | 1.0             |
| P4.06         | Reverse detection time of encoder                 | 0.0~100.0s  | 0.0~100.0     | 1.0             |

Thread break detection time of encoder is defined by P4.04 and P4.05, when the time of encoder thread break is more than setting time of encoder thread break, the inverter will show fault of encoder thread break (PCE), P4.04 corresponds to low speed, and P4.05 corresponds to high speed.

Reverse detection time of encoder is defined by P4.06, when the time of reverse time of encoder is more than corresponding thread break detection time, the system will show fault of encoder reverse encoder (PCDE).

If the detection time is set to be 0, it means the detection function been canceled.

**Note: Setting the above parameters will influence delicacy of encoder fault protection, please adjust these parameters carefully.**

| Function Code | Name                                  | Description | Setting Range | Factory Setting |
|---------------|---------------------------------------|-------------|---------------|-----------------|
| P4.07         | Magnetic pole position amplitude gain | 0.50~1.50   | 0.50~1.50     | 1.00            |
| P4.08         | C phase magnetic pole position offset | 0~1024      | 0~1024        | 512             |
| P4.09         | D phase pole position offset          | 0~1024      | 0~1024        | 512             |

The above parameters will be updated automatically after autotuning of synchronous motor; the user can not need to modify it. If the rotating autotuning is not available, this parameter should be set properly during static autotuning. Please refer to the static autotuning for detailed information.

| Function Code | Name  | Description  | Setting Range | Factory Setting |
|---------------|---|--------------|---------------|-----------------|
| P4.10         | Synchronous motor static identification current | 10.0%~100.0% | 10.0~100.0    | 50.0%           |

The angle is saved as P4.03 after the static autotuning been performed. And the actual current can display at PB.03, the current of PB.03 should be between 80%~110%. If the current value is smaller obviously, please increase P4.10. If the actual current is greater, it may report motor autotuning fault (the fault code is TE).

| Function Code | Name     | Description | Setting Range | Factory Setting |
|---------------|----------|-------------|---------------|-----------------|
| P4.11~P4.13   | Reserved | 0~65536     | 0~65335       | 0               |

## 6.6 P5 Group--Input terminals

The standard configuration of CHV108 serials frequency has 6 multi-function digital input terminals and 2 analog input terminals. If need many more input/output terminals, please choose the corresponding extension card.

| Function Code | Name                          | Description | Setting Range | Factory Setting |
|---------------|-------------------------------|-------------|---------------|-----------------|
| P5.00         | Terminal input mode selection | 0~0x3FF     | 0~0x3FF       | 0               |

The function is to select the switch signal input terminals to be natural open or natural close. It means terminal input is natural close when the corresponding bit is 1; the parameter is 16 hex setting. Switch signal corresponding bit is as follows:

|      |      |      |      |      |
|------|------|------|------|------|
| BIT9 | BIT8 | BIT7 | BIT6 | BIT5 |
| S10  | S9   | S8   | S7   | S6   |
| BIT4 | BIT3 | BIT2 | BIT1 | BIT0 |
| S5   | S4   | S3   | S2   | S1   |

| Function Code | Name                              | Description            | Setting Range | Factory Setting |
|---------------|-----------------------------------|------------------------|---------------|-----------------|
| P5.01         | Terminal function input selection | 0: Invalid<br>1: Valid | 0~1           | 0               |

The function code is used to set the input channel of the terminal.

0: Communication virtual terminal invalid. The ON-OFF signal is input through the external terminals.

1: Communication virtual terminal valid. The ON-OFF signal is set by the upper PC through serial communication.

| Function Code | Name                 | Description                         | Setting Range | Factory Setting |
|---------------|----------------------|-------------------------------------|---------------|-----------------|
| P5.02         | S1 Terminal function | Programmable multifunction terminal | 0~55          | 1               |
| P5.03         | S2 Terminal function | Programmable multifunction terminal | 0~55          | 2               |
| P5.04         | S3 Terminal function | Programmable multifunction terminal | 0~40          | 8               |
| P5.05         | S4 Terminal function | Programmable multifunction terminal | 0~40          | 9               |
| P5.06         | S5 Terminal function | Programmable multifunction terminal | 0~40          | 3               |
| P5.07         | S6 Terminal function | Programmable multifunction terminal | 0~40          | 0               |

| Function Code | Name                 | Description                         | Setting Range | Factory Setting |
|---------------|----------------------|-------------------------------------|---------------|-----------------|
|               | function             | terminal                            |               |                 |
| P5.08         | S7 Terminal function | Programmable multifunction terminal | 0~40          | 0               |
| P5.09         | S8 Terminal function | Programmable multifunction terminal | 0~40          | 0               |
| P5.10         | S9 Terminal function | Programmable multifunction terminal | 0~40          | 0               |
| P5.11         | S10Terminal function | Programmable multifunction terminal | 0~40          | 0               |

This parameter is used to set the corresponding function of the digital multi-function input terminals.

0: No function

1: Up running (FWD)

2: Down running (REV)

When the running command is controlled by terminal, the elevator's up and down commands are controlled by the terminal.

3: Examine running (EXM)

This terminal is used for selecting elevator come into EXM state, this signal works with up and down running signal, and can control elevator to carry out EXM work.

4: Emergency running (EMER)

This terminal is used to select elevator to come into EMER state, this signal works with up and down running signal, and can control elevator carry out EXM work.

5: Coast to stop (FSTP)

Inverter blockades output, motor's stopping process is not controlled by inverter. This mode has the same meaning as described in P1.29.

6: Fault reset

Exterior fault reset function, is used for far distance failure reset, and has the same function as STOP/RST key on keyboard.

7: External fault input (EF)

After this signal is available, inverter reports exterior fault (EF) and stop.

8~10: Multi-speed terminals 1~3

The combination of the three terminals can achieve the speed set in 8 steps.

**Note: Terminal 1 is for low-speed, terminal 3 is for high-speed.**

| Multi-step speed 3 | Multi- step speed 2 | Multi- step speed 1 |
|--------------------|---------------------|---------------------|
| BIT2               | BIT1                | BIT0                |

11~13: Up forced deceleration 1~3

Up forced signal is use for preventing the elevator crash to the top. Please refer to P1.23 ~ P1.28 for the description of specific function.

14 ~ 16: Down forced deceleration 1~3

Down forced signal is use for preventing the elevator clash to the bottom. Please refer to P1.23 ~ P1.28 for the description of specific function.

**Note: Up forced deceleration and down forced deceleration is one-to-one correspondence.**

17: Contactor feedback signal (TB)

P8.04 selects contactor control to be available, if contactor feedback signal is wrong, inverter will report contactor feedback fault (TbE).

18: Brake feedback signal (FB)

P8.04 selects brake control to be available, if brake feedback signal is wrong, inverter will report brake feedback fault (TbE).

19: Inverter enabling (ENA)

When a multi-functional terminal is set to be inverter enabled, the inverter can run, only after the ENA signal is available, otherwise the inverter does not respond to running command. If not choose this function, inverter default can be effective.

20: Forced deceleration stop

General forced deceleration signal has the high priority, the deceleration is decided by P1.23 (Forced deceleration speed 1), whenever running up/running down, the elevator is decelerated to stop according to the setting deceleration of P1.23 when the signal is valid.

21~40: Reserved

| Function Code | Name                       | Description | Setting Range | Factory Setting |
|---------------|----------------------------|-------------|---------------|-----------------|
| P5.12         | Switch signal filter times | 1~10        | 1~10          | 5               |

This parameter is used to set sampling filter times of terminals (S1~S10). When interference is heavy, user should increase this value to prevent malfunction.

| Function Code | Name                                  | Description    | Setting Range | Factory Setting |
|---------------|---------------------------------------|----------------|---------------|-----------------|
| P5.13         | AI1 lower limit                       | 0.00V~10.00V   | 0.00~10.00    | 0.00V           |
| P5.14         | AI1 lower limit corresponding setting | -100.0%~100.0% | -100.0~100.0  | 0.0%            |
| P5.15         | AI1 upper limit                       | 0.00V~10.00V   | 0.00~10.00    | 10.00V          |
| P5.16         | AI1 upper limit corresponding setting | -100.0%~100.0% | -100.0~100.0  | 100.0%          |
| P5.17         | AI1 filter time constant              | 0.00s~10.00s   | 0.00~10.00    | 0.10s           |

These parameters determine the relationship between analog input voltage and the corresponding setting value. When the analog input voltage exceeds the range of lower limit and upper limit, it will be regarded as the upper limit or lower limit.

When the analog input is current signal, the 4~20mA current signal correspond to 0~5V voltage signal.

For different applications, the corresponding value of 100.0% analog setting is different. For details, please refer to description of each application.

**Note: AI1 lower limit must be less or equal to AI1 upper limit.**

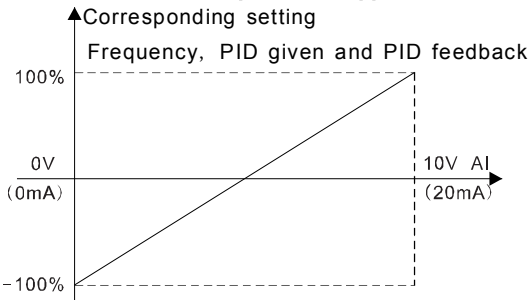

Figure 6.10 Relationship between AI and corresponding setting.

The input filter time of AI1: determine the accuracy of the analog input. This parameter can be increased to prevent the analog input from transcending and becoming instable. Then the input will be more stable but the accuracy will be reduced.

| Function Code | Name                                  | Description    | Setting Range | Factory Setting |
|---------------|---------------------------------------|----------------|---------------|-----------------|
| P5.18         | AI2 lower limit                       | 0.00V~10.00V   | 0.00~10.00    | 0.00V           |
| P5.19         | AI2 lower limit corresponding setting | -100.0%~100.0% | -100.0~100.0  | 0.0%            |
| P5.20         | AI2 upper limit                       | 0.00V~10.00V   | 0.00~10.00    | 5.00V           |
| P5.21         | AI2 upper limit corresponding setting | -100.0%~100.0% | -100.0~100.0  | 100.0%          |
| P5.22         | AI2 filter time constant              | 0.00s~10.00s   | 0.00~10.00    | 0.10s           |

Please refer to description of AI1.

The setting of AI2 function is the same as that of AI1. Analog AI2 can support 0~10V or 0~20mA input. When AI2 selects 0~20mA, the corresponding voltage of 20mA is 5V.

CHV180 series inverters have 2 ways of analog input.

## 6.7 P6 Group -- Output terminals

CHV180 series inverters have 1 way of multi-function digital input terminal, 2 way of multi-function relay output terminals and 1 way of HDO terminal (can be selected as high speed pulse output terminal and analog output terminal) as the standard configuration. If it is necessary to add relay output terminal and analog output terminal, it is available to select multi-function input/output extension card.

The multi-function input/output extension card has 1 way of multi-function relay output terminal and 1 way of multi-function analog output terminal.

| Function Code | Name                 | Description  | Setting Range | Factory Setting |
|---------------|----------------------|--|---------------|-----------------|
| P6.00         | HDO output selection | 0: High-speed pulse output<br>1: Open collector output | 0~1           | 0               |

0: Open collector High-speed pulse output: The maximum pulse frequency is 50.0 kHz.

Please refer to description of P6.09.

1: Open collector output: Please refer to description of P6.03.

**Note:** HDO terminal is for programmable multiplexing output.



| Function Code | Name                                | Description           | Setting Range | Factory Setting |
|---------------|-------------------------------------|-----------------------|---------------|-----------------|
| P6.01         | Y1 output selection                 | Open-collector output | 0~20          | 1               |
| P6.02         | Y2 output selection                 | Open-collector output | 0~20          | 0               |
| P6.03         | HDO open collector output selection | Open-collector output | 0~20          | 0               |
| P6.04         | Relay 1 output selection            | Relay output          | 0~20          | 4               |
| P6.05         | Relay 2 output selection            | Relay output          | 0~20          | 5               |
| P6.06         | Relay 3 output selection            | Relay output          | 0~20          | 0               |

Open collector output functions are indicated in the following table:

| Setting Value | Function              | Description   |
|---------------|-----------------------|---|
| 0             | No output             | No function.  |
| 1             | Elevator running(LR)  | ON: During run.   |
| 2             | Up running            | ON: During running up.  |
| 3             | Down running          | ON: During running down.  |
| 4             | Fault output          | ON: When fault occur.   |
| 5             | Zero speed running    | ON: When the output speed and setting speed are zero during running.  |
| 6             | Running is ready      | ON: Inverter is ready (no fault, power is ON).  |
| 7             | Holding-brake control | When the P8.04 is set to be 1, it will output the brake signal<br>ON: take off the brake.<br>OFF: hold the brake. |
| 8             | Contactors control    | ON: close the contactor.<br>OFF: open the contactor.  |

| Setting Value | Function                 | Description  |
|---------------|--------------------------|--|
| 9             | Frequency reached        | Please refer to the description of P6.24.                          |
| 10            | FDT reached              | Please refer to the description of P6.22 and P6.23.                |
| 11            | Elevator running 1 (LR1) | ON: From brake-releasing delay finished to closing brake finished. |
| 12            | Holding-brake output     | ON: From brake-closing delay finished to stop                      |
| 13~20         | Reserved                 | Reserved   |

**Note:** Multi-function output terminal 11 and 12 are mainly used when: when the barking is used external control, it will inform the control system to close or release the braking. Please refer to figure 8.2 for the detailed logic.

| Function Code | Name   | Description | Setting Range | Factory Setting |
|---------------|--|-------------|---------------|-----------------|
| P6.07         | AO1 output selection                                 | 0~14        | 0~14          | 0               |
| P6.08         | AO2 output selection                                 | 0~14        | 0~14          | 0               |
| P6.09         | HDO open collector high speed pulse output selection | 0~14        | 0~14          | 0               |

The standard output of AO1 and AO2 is 0~10V/0~20mA, which can be selected by J19 jumper wire. The range of P6.09 is from 0 kHz to 50.kHz.

AO/HDO output functions are indicated in the following table:

| Setting Value | Function            | Range                              |
|---------------|---------------------|------------------------------------|
| 0             | Running speed       | 0~Elevator rated speed             |
| 1             | Reference speed     | 0~Elevator rated speed             |
| 2             | Motor running speed | 0~2* motor rated synchronous speed |
| 3             | Output current      | 0~2* inverter rated current        |
| 4             | Output voltage      | 0~2* inverter rated voltage        |
| 5             | Output power        | 0~2* rated power                   |

| Setting Value | Function      | Range             |
|---------------|---------------|-------------------|
| 6             | Output torque | 0~2*rated current |
| 7             | AI1 input     | 0~10V             |
| 8             | AI2 input     | 0~10V/0~20mA      |
| 9~14          | Reserved      | Reserved          |

| Function Code | Name                                 | Description   | Setting Range | Factory Setting |
|---------------|--------------------------------------|---------------|---------------|-----------------|
| P6.10         | AO1 lower limit                      | 0.0%~P6.12    | 0.0~ P6.12    | 0.0%            |
| P6.11         | AO1 lower limit corresponding output | 0.00V ~10.00V | 0.00~10.00    | 0.00V           |
| P6.12         | AO1 upper limit                      | 0.0%~100.0%   | P6.10~100.0   | 100.0%          |
| P6.13         | AO1 upper limit corresponding output | 0.00V ~10.00V | 0.00~10.00    | 10.00V          |
| P6.14         | AO2 lower limit                      | 0.0%~ P6.16   | 0.0~ P6.16    | 0.0%            |
| P6.15         | AO2 lower limit corresponding output | 0.00V ~10.00V | 0.00~10.00    | 0.00V           |
| P6.16         | AO2 upper limit                      | 0.0%~100.0%   | P6.14~100.0   | 100.0%          |
| P6.17         | AO2 upper limit corresponding output | 0.00V ~10.00V | 0.00~10.00    | 10.00V          |
| P6.18         | HDO lower limit                      | 0.0%~ P6.20   | 0.0~ P6.20    | 0.0%            |
| P6.19         | HDO lower                            | 0.0 ~ 50.0kHz | 0.0~50.0      | 0.0kHz          |

| Function Code | Name  | Description   | Setting Range | Factory Setting |
|---------------|---|---------------|---------------|-----------------|
|               | limit<br>corresponding<br>output              |               |               |                 |
| P6.20         | HDO upper<br>limit                            | 0.0%~100.0%   | P6.18~100.0   | 100.0%          |
| P6.21         | HDO upper<br>limit<br>corresponding<br>output | 0.0 ~ 50.0kHz | 0.0~50.0      | 50.0kHz         |
| P6.22         | FDT level<br>detection<br>value               | 0.00~P0.04    | 0.00~P0.04    | 50.00Hz         |
| P6.23         | FDT lag<br>detection<br>value                 | 0.0~100.0     | 0.0~100.0     | 5.0%            |

These parameters are used to set the detection value of the output frequency and the lag value of the output action releasing.

The corresponding relationship of A02 output is similar to that of A01. High speed pulse output is illustrated as below:

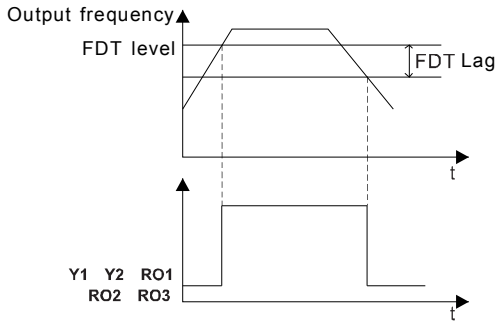

Figure 6.14 FDT Level diagram.

| Function Code | Name                              | Description | Setting Range | Factory Setting |
|---------------|-----------------------------------|-------------|---------------|-----------------|
| P6.24         | Frequency arrival detecting range | 0.00~100.0% | 0.00~100.0    | 0.0%            |

When output frequency reaches reference frequency, it can adjust the detection amplitude. Description as follow:

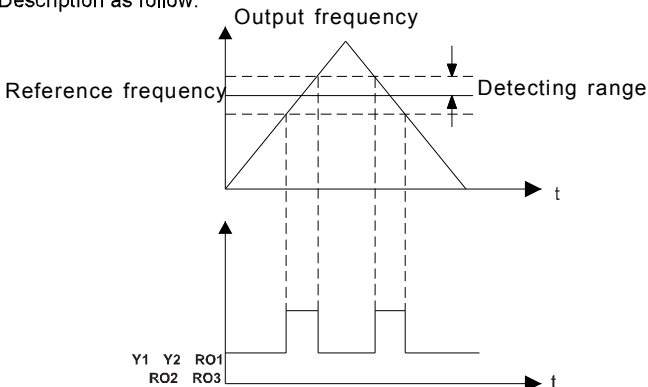

Figure 6.15 Frequency arriving detection diagram.

| Function Code | Name     | Description | Setting Range | Factory Setting |
|---------------|----------|-------------|---------------|-----------------|
| P6.25         | Reserved | 0~65536     | 0~65536       | 0               |

| Function Code | Name | Description | Setting Range | Factory Setting |
|---------------|------|-------------|---------------|-----------------|
| P6.26         |      | 0~65536     | 0~65536       | 0               |

## 6.8 P7 Group –Human-Machine interface

| Function Code | Name          | Description | Setting Range | Factory Setting |
|---------------|---------------|-------------|---------------|-----------------|
| P7.00         | User password | 0~65535     | 0~65535       | 0               |

The password protection function will be valid when it is set to be any nonzero data. When P7.00 is set to be 00000, the user's password set before will be cleared and the password protection function will be disabled.

After the password has been set and becomes valid, the user can not access menu if the user's password is not correct. Only when a correct user's password is input, the user can see and modify the parameters. Please keep user's password in mind.

| Function Code | Name                   | Description  | Setting Range | Factory Setting |
|---------------|------------------------|--|---------------|-----------------|
| P7.01         | LCD language selection | 0: Chinese<br>1: English   | 0~1           | 0               |
| P7.02         | Parameter copy         | 0: Invalid<br>1: Upload parameters to LCD<br>2: Download parameters from LCD | 0~2           | 0               |

P7.02 will take effect when LCD keypad is used.

1: All value of parameters will be uploaded from inverter to LCD keypad

2: All value of parameters will be downloaded from LCD keypad to inverter.

**Note: When upload or download operation is completed; P7.02 will be set to 0 automatically. The function will be reserve temporary.**

| Function Code | Name                                | Description                                | Setting Range | Factory Setting |
|---------------|-------------------------------------|--|---------------|-----------------|
| P7.03         | <b>QUICK/JOG</b> function selection | 0: Examine running<br>1: FDW/REV switching | 0~1           | 0               |

**QUICK/JOG** is a multifunctional key, whose function can be defined by the value of P7.03.

0: Examine running

1: FWD/REV switching

| Function Code | Name                                  | Description   | Setting Range | Factory Setting |
|---------------|---------------------------------------|---|---------------|-----------------|
| P7.04         | <b>STOP/RST</b><br>function selection | 0: Valid only when keypad control (P0.01=0)<br>1: Valid when keypad or terminal control (P0.01=0 or 1)<br>2: Valid when keypad or communication control (P0.01=0 or 2)<br>3: Always valid | 0~3           | 0               |

**Note:**

The reset function of **STOP/RST** is always valid.

| Function Code | Name                     | Description  | Setting Range | Factory Setting |
|---------------|--------------------------|--|---------------|-----------------|
| P7.05         | Keypad display selection | 0: Priority to external keypad<br>1: Both display, only external key valid.<br>2: Both display, only local key valid<br>3: Both display and key valid. | 0~3           | 0               |

0: When external keypad exists, local keypad will be invalid.

1: Local and external keypad display simultaneously, only the key of external keypad is valid.

2: Local and external keypad display simultaneously, only the key of local keypad is valid.

3: Local and external keypad display simultaneously, both keys of local and external keypad are valid. **This function should be used cautiously, otherwise it may cause malfunction.**

**Note:**

















- When P7.05 is set to be 1, local keypad is valid if external keypad is not connected.
- When LCD keypad is connected, P7.05 must be set to be 0.

| Function Code | Name                            | Description | Setting Range | Factory Setting |
|---------------|---------------------------------|-------------|---------------|-----------------|
| P7.06         | Running state display selection | 0x00FF      | 0~0x03FF      | 0x00FF          |

In the running state, CHV180 series inverters can display 5 parameters: running speed, set speed, bus voltage, output voltage and output current.

The displayings of other parameters are determined by the function code. If Bit is 0, the parameter will not be displayed; If Bit is 1, the parameter will be displayed. Press  **[SHIFT]** to scroll through these parameters in right order. Setting function code P7.06, binary numbers should be changed into hex numbers.

The display content corresponding to each bit of P7.06 is described in the following:

|  |  |  |  |  |  |  |  |
|---|---|---|---|---|---|---|---|
| AI2   | AI1   | Output terminal state   | Input terminal state  | Output torque   | Output power  | Rotation speed  | Running frequency   |
|  |  |  |  |  |  |  |  |
| Reserved  | Reserved  | Reserved  | Reserved  | Reserved  | Reserved  | Pole position   | Torque compensation   |

**Note: I/O terminal state is displayed in decimal.** For details, please refer to description of P7.19 and P7.20.

| Function Code | Name                         | Description | Setting Range | Factory Setting |
|---------------|------------------------------|-------------|---------------|-----------------|
| P7.07         | Stop state display selection | 0~0x01FF    | 0~0x01FF      | 0x00FF          |

P7.07 determines the display parameters in stop state. The setting method is similar with P7.06.

The display content corresponding to each bit of P7.07 is described in the following table:



|              |              |              |                       |                      |                |                     |                 |
|--------------|--------------|--------------|-----------------------|----------------------|----------------|---------------------|-----------------|
| <b>BIT7</b>  | <b>BIT6</b>  | <b>BIT5</b>  | <b>BIT4</b>           | <b>BIT3</b>          | <b>BIT2</b>    | <b>BIT1</b>         | <b>BIT0</b>     |
| AI2          | AI1          | Motor poles  | Output terminal state | Input terminal state | DC bus voltage | Reference frequency | Reference speed |
| <b>BIT15</b> | <b>BIT14</b> | <b>BIT13</b> | <b>BIT12</b>          | <b>BIT11</b>         | <b>BIT10</b>   | <b>BIT9</b>         | <b>BIT8</b>     |
| Reserved     | Reserved     | Reserved     | Reserved              | Reserved             | Reserved       | Reserved            | Pole position   |

| Function Code | Name                         | Description | Setting Range | Factory Setting |
|---------------|------------------------------|-------------|---------------|-----------------|
| P7.08         | Rectifier module temperature | 0~100.0℃    |               |                 |
| P7.09         | IGBT module temperature      | 0~100.0℃    |               |                 |
| P7.10         | MCU software version         |             |               |                 |
| P7.11         | DSP software version         |             |               |                 |
| P7.12         | Accumulated running time     | 0~65535h    |               |                 |

Rectifier module temperature: Indicates the temperature of rectifier module. Overheat protection point of different inverter may be different.

IGBT module temperature: Indicates the temperature of IGBT module. Overheat protection point of different inverter may be different.

MCU Software version: Indicates current software version of MCU.

DSP Software version: Indicates current software version of DSP

Accumulated running time: Displays accumulated running time of inverter.

**Note: Above parameters are read only.**

| Function Code | Name                    | Description | Setting Range | Factory Setting |
|---------------|-------------------------|-------------|---------------|-----------------|
| P7.13         | Previous two fault type | 0~31        | 0~31          | Reserved        |
| P7.14         | Previous fault type     | 0~31        | 0~31          |                 |

| Function Code | Name                    | Description | Setting Range | Factory Setting |
|---------------|-------------------------|-------------|---------------|-----------------|
| P7.13         | Previous two fault type | 0~31        | 0~31          | Reserved        |
| P7.14         | Previous fault type     | 0~31        | 0~31          |                 |
| P7.15         | Current fault type      | 0~31        | 0~31          |                 |

These parameters record three recent fault types. 0 means no fault, 1~31 shows different fault types.

For details, please refer to description of chapter 8.

| Function Code | Name                                   | Description                        | Setting Range | Factory Setting |
|---------------|--|------------------------------------|---------------|-----------------|
| P7.16         | Output frequency at current fault      | Output frequency at current fault. |               |                 |
| P7.17         | Output current at current fault        | Output current at current fault.   |               |                 |
| P7.18         | DC bus voltage at current fault        | DC bus voltage at current fault.   |               |                 |
| P7.19         | Input terminal state at current fault  |                                    |               |                 |
| P7.20         | Output terminal state at current fault |                                    |               |                 |

The state of the current fault input terminal is decimal number. Display the state of all digital input terminals at the latest fault, the sequence is:

|             |             |             |             |             |
|-------------|-------------|-------------|-------------|-------------|
| <b>BIT9</b> | <b>BIT8</b> | <b>BIT7</b> | <b>BIT6</b> | <b>BIT5</b> |
| S10         | S9          | S8          | S7          | S6          |
| <b>BIT4</b> | <b>BIT3</b> | <b>BIT2</b> | <b>BIT1</b> | <b>BIT0</b> |
| S5          | S4          | S3          | S2          | S1          |

When the input terminal is ON, its corresponding bit is 1, and the corresponding bit of OFF is 0.

This value can inform the state of digital input signal at fault.

The state of the current fault input terminal is decimal number. Display the state of all digital input terminals at the latest fault, the sequence is:

|      |      |      |      |      |      |
|------|------|------|------|------|------|
| BIT5 | BIT4 | BIT3 | BIT2 | BIT1 | BIT0 |
| RO3  | RO2  | RO1  | HDO  | Y2   | Y1   |

1 indicates corresponding output terminal is ON, while 0 indicates OFF.

**Note: This value is displayed as decimal.**

| Function Code | Name     | Description | Setting Range | Factory Setting |
|---------------|----------|-------------|---------------|-----------------|
| P7.21         | Reserved | 0~65536     | 0~65536       | 0               |
| P7.22         | Reserved | 0~65536     | 0~65536       | 0               |

### 6.9 P8 Group --Enhanced function

| Function Code | Name                                | Description                        | Setting Range | Factory Setting |
|---------------|-------------------------------------|------------------------------------|---------------|-----------------|
| P8.00         | Analog weigh signal input selection | 0: No function<br>1: AI1<br>2: AI2 | 0~2           | 0               |

This parameter can improve start comfortable of elevator.

**Note: This analog signal can't use the same analog input source with speed command selection (P0.03)**

| Function Code | Name              | Description | Setting Range | Factory Setting |
|---------------|-------------------|-------------|---------------|-----------------|
| P8.01         | Pre-torque offset | 0.0~100.0%  | 0.0~100.0     | 30.0%           |
| P8.02         | Drive side gain   | 0.000~7.000 | 0.000~7.000   | 1.000           |
| P8.03         | Brake side gain   | 0.000~7.000 | 0.000~7.000   | 1.000           |

When elevator is running, the start comfortable is improved by pre-torque compensating difference value of elevator car and counterpoise. Only when P8.00 isn't set to be 0, pre-torque compensation will be available. The detailed way and size are as follow:

| Direction running | Comparison         | Pre-torque compensation value |
|-------------------|--------------------|-------------------------------|
| Up running        | Car > counterpoise | P8.02*(car - P8.01)           |
|                   | Car < counterpoise | P8.03*( car - P8.01)          |

| Direction running | Comparison         | Pre-torque compensation value |
|-------------------|--------------------|-------------------------------|
| Up running        | Car > counterpoise | P8.02*(car - P8.01)           |
|                   | Car < counterpoise | P8.03*( car - P8.01)          |
| Down running      | Car > counterpoise | P8.03*( car - P8.01)          |
|                   | Car < counterpoise | P8.02*( car - P8.01)          |

The car weight is weighted by simulation weighing transducer (include the load)

P8.01= (counterpoise weight-car weight)/ rated load weight of elevator.

| Function Code | Name                                       | Description  | Setting Range | Factory Setting |
|---------------|--|--|---------------|-----------------|
| P8.04         | Holding brake, contactor control selection | 0: Holding brake and contactor are controlled by exterior controller, not inverter.<br>1: Holding brake is controlled by inverter, and contactor is controlled by exterior controller.<br>2: Holding brake is controlled by exterior controller, and contactor is controlled by inverter.<br>3: Both holding brake and contactor are controlled by inverter. | 0~3           | 0               |
| P8.05         | Close brake delay time                     | 0.00~5.00s   | 0.00~5.00     | 0               |
| P8.06         | Open brake delay time                      | 0.00~5.00s   | 0.00~5.00     | 0               |

Close brake delay time is from the output frequency reaches P8.13 to output close brake command. This parameter can improve stop comfortable.

Open brake delay time is from 0 speed running to output Open brake command. This parameter let inverter prevent starting concussion, before open brake.

Note:

The delay of close brake and open brake are always effect, they are not matter with the close brake and contactor control mode.

| Function Code | Name                    | Description  | Setting Range | Factory Setting |
|---------------|-------------------------|--------------|---------------|-----------------|
| P8.07         | Brake threshold voltage | 560.0~750.0V | 560.0~750.0   | 700.0           |

This function code is to set the threshold DC bus voltage when dynamic braking, set the parameter correctly can improve the performance of braking.

| Function Code | Name                   | Description | Setting Range | Factory Setting |
|---------------|------------------------|-------------|---------------|-----------------|
| P8.08         | Fault auto reset times | 0~10        | 0~10          | 0               |
| P8.09         | Fault relay action     | 0~1         | 0~1           | 0               |
| P8.10         | Reset interval         | 0.1~100.0s  | 0.1~100.0     | 1.0s            |

Automatic fault reset time: if the time is not set to 0, this function is valid. But when the continuous time exceeds this value, the inverter will stop for fault.

Fault relay action during automatic fault reset: this parameter is used to select whether need fault relay action or not during the fault reset after selecting the fault reset function.

This function can avoid the fault alarm and keep on working.

Fault reset interval: this parameter is used to select the interval from the fault occurring to fault reset.

0: Relay no action

1: Relay action

| Function Code | Name  | Description | Setting Range | Factory Setting |
|---------------|---|-------------|---------------|-----------------|
| P8.11         | Contacting brake feedback inspecting interval | 0.1~5.0s    | 0.1~5.0       | 2.0             |

After selecting contracting brake control, the fault time of elevator contracting brake action is greater than P8.11, inverter will report brake feedback fault (FAE).

| Function Code | Name      | Description | Setting Range | Factory Setting |
|---------------|-----------|-------------|---------------|-----------------|
| P8.12         | Contactor | 0.1~5.0s    | 0.1~5.0       | 2.0             |

| Function Code | Name                         | Description | Setting Range | Factory Setting |
|---------------|------------------------------|-------------|---------------|-----------------|
|               | feedback inspecting interval |             |               |                 |

After selecting contactor control, the fault time of elevator relay action is greater than P8.12, inverter will report contactor feedback fault (TbE).

| Function Code | Name                             | Description | Setting Range | Factory Setting |
|---------------|----------------------------------|-------------|---------------|-----------------|
| P8.13         | Stop contracting brake frequency | 0.00~5.00Hz | 0.00~5.00     | 0.00            |

This frequency is just set the point with the inverter should break. If set P8.05, and it starts timing when the inverter output frequency reaches the frequency point, output the contracting brake signal when the time is over. The closing brake and contracting brake of multi-function, output function been blocked at the same time. If P8.05 is set to be 0, when the inverter output frequency reaches setting frequency point, contracting brake is carried out immediately.

| Function Code | Name                   | Description | Setting Range | Factory Setting |
|---------------|------------------------|-------------|---------------|-----------------|
| P8.14         | Start DC brake current | 0.0~120%    | 0.0~120       | 0.0             |
| P8.15         | Start DC brake time    | 0.0~50.0s   | 0.0~50.0      | 0.0             |

During starting, the inverter will perform DC braking at the set starting DC braking current, after the time set by P8.15, it will accelerate.

When inverter is starting, DC brake is carried out according to the setting of P8.14 and it is accelerated to run when the setting start DC brake time is reached. If P8.15 is set to be 0, DC brake is invalid. The bigger DC brake current is, the bigger braking torque will be.

P8.15 should be greater than P8.06 when selecting first function of starting after DC braking.

| Function Code | Name                          | Description | Setting Range | Factory Setting |
|---------------|-------------------------------|-------------|---------------|-----------------|
| P8.16         | Stop brake starting frequency | 0.00~P0.04  | 0.00~P0.04    | 0.00            |
| P8.17         | Stop brake waiting time       | 0.0~50.0s   | 0.0~50.0      | 0.0             |
| P8.18         | Stop DC brake current         | 0.0~120%    | 0.0~120       | 0.0             |
| P8.19         | Stop DC brake time            | 0.0~50.0s   | 0.0~50.0      | 0.0             |

Stop brake starting frequency: when the shutdown mode is deceleration to stop(P1.29=0), it starts DC brake when the frequency point is reached, and it is considered zero running in internal inverter, and the close brake delay start to timing.

**Note: Stop DC brake is only effect when it is decelerated to stop (P1.29=0).The inverter is considered zero running when DC brake; both close brake delay and open brake delay are effect.**

| Function Code | Name           | Description | Setting Range | Factory Setting |
|---------------|----------------|-------------|---------------|-----------------|
| P8.20         | Stopping delay | 0.0~5.0s    | 0.0~5.0s      | 0.0s            |

The function is primarily to avoid that the brake is not closed steadily enough when inverter stops.

When P1.29 is set to be 1,in the process of running, then there is a signal of coast to stop ,inverter brake immediately to block output without stop delay time, when inverter run to zero speed and brake, after the stop delay time, inverter block output.

When P1.29 is set to be 0(deceleration to stop), inverter will block output after the delay time whenever inverter decelerate to stop.

| Function Code | Name                                 | Description | Setting Range | Factory Setting |
|---------------|--------------------------------------|-------------|---------------|-----------------|
| P8.21         | Two/Three-phase modulation selection | 0~1         | 0~1           | 1               |

0: Two-phase modulation, the noise of running motor is lower, but the temperature rise quickly, inverter need to derating in this mode.

1: Three-phase modulation, the noise of running motor is bigger, but it is better for the

inhibition of motor oscillation in this mode.

| Function Code | Name     | Description | Setting Range | Factory Setting |
|---------------|----------|-------------|---------------|-----------------|
| P8.22         | Reserved | 0~65535     | 0~65535       | 0               |
| P8.23         | Reserved | 0~65535     | 0~65535       | 0               |

## 6.10 P9 Group -- Protection parameters

| Function Code | Name                            | Description               | Setting Range | Factory Setting |
|---------------|---------------------------------|---------------------------|---------------|-----------------|
| P9.00         | Input phase-failure protection  | 0: Disabled<br>1: Enabled | 0~1           | 1               |
| P9.01         | Output phase-failure protection | 0: Disabled<br>1: Enabled | 0~1           | 1               |

| Function Code | Name                      | Description   | Setting Range | Factory Setting |
|---------------|---------------------------|---|---------------|-----------------|
| P9.02         | Motor overload protection | 0: Disabled<br>1: Normal motor<br>2: Variable frequency motor | 0~2           | 2               |

1: For normal motor (within the function of low speed compensation), the lower the speed, the poorer the cooling effect. Based on this reason, if output frequency is lower than 30Hz, inverter will reduce the motor overload protection threshold to prevent normal motor from overheat.

2: For variable frequency motor (without the function of low speed compensation), As the cooling effect of variable frequency motor has nothing to do with running speed, it is not required to adjust the motor overload protection threshold.

| Function Code | Name                              | Description  | Setting Range | Factory Setting |
|---------------|-----------------------------------|--------------|---------------|-----------------|
| P9.03         | Motor overload protection current | 20.0%~120.0% | 20.0~120.0    | 100.0%          |



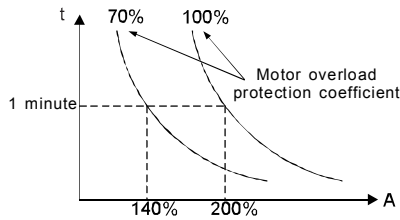

Figure 6.16 Motor overload protection curves.

The value can be determined by the following formula:

$$\text{Motor overload protection current} = (\text{motor rated current} / \text{inverter rated current}) * 100\%$$

**Note:**This parameter is normally used when rated power of inverter is greater than rated power of motor.

| Function Code | Name                            | Description  | Setting Range | Factory Setting |
|---------------|---------------------------------|--|---------------|-----------------|
| P9.04         | Overload pre-warning threshold  | 20.0%~150.0%   | 20.0~150.0    | 130.0%          |
| P9.05         | Overload pre-warning selection  | 0: Always detect relative to motor rated current<br>1: Detect while constant speed relative to motor rated current<br>2: Always detect relative to inverter rated current<br>3: Detect while constant speed relative to inverter rated current | 0~3           | 0               |
| P9.06         | Overload pre-warning delay time | 0.0~30.0s  | 0.0~30.0      | 5.0s            |

The value of P9.05 determines the pre-warning category, such as motor overload (OL1) or inverter overload (OL2).

P9.04 determines the current threshold of pre-warning action, it is a percentage of the rated current. When output current of inverter exceeds the value of P9.04 and last the duration determined by P9.06, inverter will output a pre-warning signal. Please refer to

following diagram:

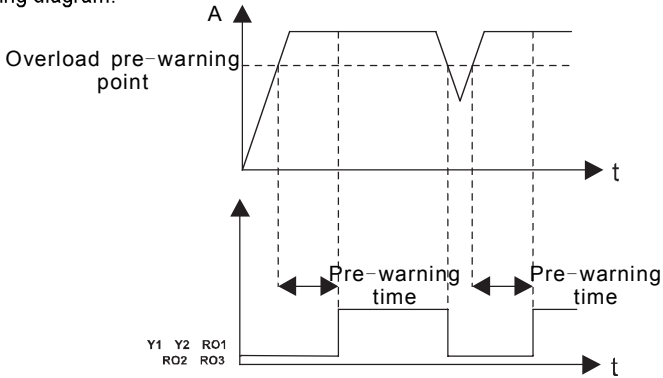

Figure 6.17 Overload pre-warning schematic diagram.

| Function Code | Name                                   | Description   | Setting Range | Factory Setting |
|---------------|--|---------------|---------------|-----------------|
| P9.07         | Threshold of over speed deviation      | 0.0%~50%      | 0.0~50        | 20.0%           |
| P9.08         | Detection time of over speed deviation | 0.000~10.000s | 0.000~10.000  | 0.5000          |

The parameter defines the protection point of over speed deviation, and is main for prevent runaway of motor whose corresponding fault code is dEV. The speed threshold fault detection is not carried out when detection time is set to be 0.

| Function Code | Name     | Description | Setting Range | Factory Setting |
|---------------|----------|-------------|---------------|-----------------|
| P9.08         | Reserved | 0~65536     | 0             | Reserved        |

### 6.11 PA Group --Serial communication

| Function Code | Name                        | Description | Setting Range | Factory Setting |
|---------------|-----------------------------|-------------|---------------|-----------------|
| PA.00         | Local communication address | 0~247       | 0~247         | 1               |

When the master is writing the frame, if the communication address of the slave is set

to be 0 (that is the broadcast communication address), all slaves on the MODBUS bus will receive the frame, but the slaves will not make any response. Note that the slave address should not be set to be 0.

The local communication address is a unique address in the communication network. This is the basis for point-to-point communications between the upper computer and the inverter.

| Function Code | Name                              | Description  | Setting Range | Factory Setting |
|---------------|-----------------------------------|--|---------------|-----------------|
| PA.01         | Communication baud rate selection | 0: 1200BPS<br>1: 2400BPS<br>2: 4800BPS<br>3: 9600BPS<br>4: 19200BPS<br>5: 38400BPS | 0~5           | 4               |

This parameter is used to set the data transmission rate between the upper computer and the inverter.

**Note: The baud rate setting of the upper computer should be the same as that of the inverter. Otherwise, communications cannot be implemented. The higher the baud rate, the faster the communication speed is.**

| Function Code | Name        | Description   | Setting Range | Factory Setting |
|---------------|-------------|---|---------------|-----------------|
| PA.02         | Data format | 0: No parity (8,N,2) for RTU<br>1: Even parity (8,E,1) for RTU<br>2: Odd parity (8,O,1) for RTU<br>3: No parity (8,N,2) for ASCII<br>4: Even parity (8,E,1) for ASCII<br>5: Odd parity (8,O,1) for ASCII<br>6: No parity (7,N,2) for ASCII<br>7: Even parity (7,E,1) for ASCII<br>8: Odd parity (7,O,1) for ASCII | 0~8           | 1               |

The data format setting of the upper computer should be the same as that of the inverter. Otherwise, communications cannot be implemented.

| Function Code | Name                         | Description | Setting Range | Factory Setting |
|---------------|------------------------------|-------------|---------------|-----------------|
| PA.03         | Communication response delay | 0~20ms      | 0~20          | 0ms             |

Reply delay: refers to the interval time between the end of data receiving of the inverter and the reply data sending of the upper computer. If the reply delay time is less than the system processing time, take the system processing time as reply delay reference. If the reply delay is longer than the system processing time, after data processing, the system has to wait until the reply delay time is reached before sending data to the upper computer.

| Function Code | Name                        | Description | Setting Range | Factory Setting |
|---------------|-----------------------------|-------------|---------------|-----------------|
| PA.04         | Communication timeout fault | 0.0~100.0s  | 0.0~100.0     | 0.0s            |

If the functional code is set to 0.0s, the communication delay time parameter is disabled.

When the functional code is set to be a valid value, if the interval between the current communication and the next communication exceeds the communication delay time, the system will send a communication fault error (Err18).

Normally, it is set to be "disabled". If this parameter is set in a consecutive communication system, communication state can be monitored.

| Function Code | Name                                  | Description | Setting Range | Factory Setting |
|---------------|---------------------------------------|-------------|---------------|-----------------|
| PA.05         | Communication reply enabled selection | 0~1         | 0~1           | 0               |

0: communication reply enabled

1: communication reply disabled

Selecting whether replying or not to master command.

| Function Code | Name     | Description | Setting Range | Factory Setting |
|---------------|----------|-------------|---------------|-----------------|
| PA.06         | Reserved | 1~127       | 1~127         | 1               |
| PA.07         | Reserved | 0~6         | 0~6           | 4               |

| Function Code | Name     | Description | Setting Range | Factory Setting |
|---------------|----------|-------------|---------------|-----------------|
| PA.06         | Reserved | 1~127       | 1~127         | 1               |
| PA.07         | Reserved | 0~6         | 0~6           | 4               |
| PA.08~PA.11   | Reserved | 0~65535     | 0~65535       | 0               |

CAN communication is reserved.

## 6.12 Pb Group – Display monitor

| Function Code | Name                | Description           | Setting Range | Factory Setting |
|---------------|---------------------|-----------------------|---------------|-----------------|
| Pb.00         | Running frequency   | 0.0~Maximum frequency |               |                 |
| Pb.01         | Reserved            | 0~65535               |               |                 |
| Pb.02         | Pole position angle | 0.0~359.9             |               |                 |

The parameters display the running frequency, pole position angle, the function codes are read only.

| Function Code | Name  | Description | Setting Range | Factory Setting |
|---------------|---|-------------|---------------|-----------------|
| Pb.03         | Synchronizer static identify actual current value | 0.0%~200.0% | 0.0~200.0     |                 |

It displays the actual output current value when the synchronizer is performing static autotuning, and the function code is read only.

| Function Code | Name             | Description | Setting Range | Factory Setting |
|---------------|------------------|-------------|---------------|-----------------|
| Pb.04         | Mechanical angle | 0.0~359.9   | 0.0~359.9     |                 |
| Pb.05         | Reserved         | Reserved    |               |                 |

It displays the present mechanical angle for synchronizer, and it is read only.

| Function Code | Name                                  | Description | Setting Range | Factory Setting |
|---------------|---------------------------------------|-------------|---------------|-----------------|
| Pb.06         | AD detection value of encoder C phase | 0~1024      |               |                 |
| Pb.07         | AD detection value of encoder D phase | 0~1024      |               |                 |

The parameters display the sampling value of present encoder signal, the function codes are used to correct zero-bias of encoder (P4.08,P4.09) when the synchronizer performs static autotuning.

| Function Code | Name     | Description | Setting Range | Factory Setting |
|---------------|----------|-------------|---------------|-----------------|
| Pb.08~Pb.09   | Reserved | Reserved    |               |                 |

### 6.13 PC Group –Load starting parameters

| Function Code | Name                             | Description           | Setting Range | Factory Setting |
|---------------|----------------------------------|-----------------------|---------------|-----------------|
| PC.00         | No weighting compensation enable | 0:Disable<br>1:Enable | 0~1           | 0               |
| PC.01         | Load compensation time           | 0.000~5.000s          | 0.000~5.000   | 0.500s          |

During the load compensation time, speed loop ASR PI selects PC.03 and PC.04, and position loop PC.05 and PC.06 are effective. The parameter starts timing from receiving running command, and it is generally set to be zero speed holding time.

| Function Code | Name                         | Description  | Setting Range | Factory Setting |
|---------------|------------------------------|--------------|---------------|-----------------|
| PC.02         | Load compensation lower time | 0.000~5.000s | 0.000~5.000s  | 0.300s          |

The parameter is the transition time of ASR from PC.03 and PC.04 to P3.00 and

## P3.01.

| Function Code | Name                                  | Description | Setting Range | Factory Setting |
|---------------|---------------------------------------|-------------|---------------|-----------------|
| PC.03         | Load compensation ASR proportion gain | 0~100       | 0~100         | 30              |
| PC.04         | Load compensation ASR integral gain   | 0.01~10.00s | 0.01~10.00s   | 0.04s           |
| PC.05         | Position loop APR proportion gain     | 0~100       | 0~100         | 0               |
| PC.06         | Position loop APR differential gain   | 0.01~10.00s | 0.01~10.00    | 0.00s           |

The position loop PC.05 and PC.06 are needn't to be set usually. The motor may oscillation easily. If the set of Pc.05 is too large Please adjust PC.03 and PC.04 properly. Increase PC.04 if the motor is oscillating. Decrease PC.04 or increase PC.03 if the stroll down and overshoot of elevator happen when starting.

| Function Code | Name                             | Description | Setting Range | Factory Setting |
|---------------|----------------------------------|-------------|---------------|-----------------|
| PC.07         | Current compensation coefficient | 0~2000      | 0~2000        | 1000            |

The parameter is only effective when PC.01 is valid. If the stroll down and overshoot of elevator is happened when starting, and the adjustment of PC.03 and PC.04 generates oscillation possibly. The oscillation can be eliminated when PC.07 is increased properly, usually 1000 is OK. If the motor oscillation is happened when starting because of PC.04 is too small, PC.07 can be increased to eliminate the oscillation.

| Function Code | Name                               | Description | Setting Range | Factory Setting |
|---------------|------------------------------------|-------------|---------------|-----------------|
| PC.08         | Current command filter coefficient | 0~65536     | 0~65536       | 1000            |

Bit0 and Bit1 are current loop filter parameters. The response of system will be decreased when they are increased, The parameter usually is adjusted with speed loop P3.02 and P3.06, If there is abnormal noise when the motor is running, the noise can be eliminated by increasing the parameter or P3.02 and P3.06. Bit2~bit5 are reserved.

#### 6.14 Pd Group –Factory setting

This group is only used for inverter manufacture, please don't try to open and change the parameters, otherwise may cause the inverter couldn't work or damage.



## 7. Extension card

### 7.1 Description of communication card

#### 7.1.1 Model

The communication card of CHV180 series inverters are PN000TXWX. The communication card provides RS232 and RS485 for users to select.

#### 7.2 Installation

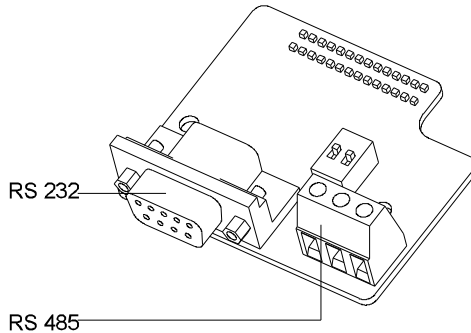

Figure 7.1 Communication card.

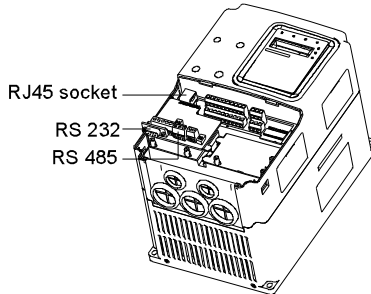

Figure 7.2 Installation of communication card.

#### 7.1.3 Usage of the communication card

When the communication between the inverter and the upper monitor is needed, the external extension card with communication interface is selected. The communication card provides RS232 and RS485 for users. The electrical parameters comply with the internal standard completely, so the communication between the upper monitor and the inverter is smooth enough and the user can select corresponding channel.

#### 7.1.4 Wiring Terminals

There are 2 groups of wiring terminals.

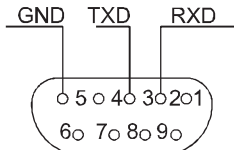

Figure 7.3 DB9: Bus-connector wiring terminal (RS232)

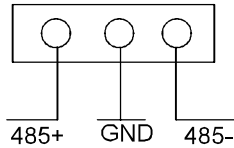

Figure 7.4 RS485 wiring terminal

### 7.1.5 Wiring precautions

Please install the card when the inverter is disconnected completely.

Please connect the communication card with the slot of the control board with proper techniques.

Tighten the communication card with screws.

In order to avoid the external interference of the communication signal, please select twisted pairs and avoid the parallel route of the drive power.

Please select shield cables as the communication connection.

## 7.2 Description of I/O extension card

### 7.2.1 Terminals instruction of IO extension card

| Terminal name | Usage and instruction   |
|---------------|---|
| S6~S8         | ON-OFF signal input, optical coupling isolation input terminal with PW and COM.<br>Input voltage range: 9~30V<br>Input impedance: 3.3kΩ   |
| HDI2          | High speed pulse or open collector input, optical coupling isolation input terminal with PW and COM.<br>Pulse input frequency: 0~50kHz<br>Input voltage: 9~30V<br>Input impedance:1.1kΩ |
| COM           | Common ground terminal for +24V or external power supply  |
| AI3           | Analog input, voltage range: -10V~10V<br>Input impedance:10kΩ   |
| AI4           | Analog input: 0~10V/0~20mA selected by J1   |

| Terminal name        | Usage and instruction   |
|----------------------|---|
|                      | Input impedance:10k $\Omega$ (voltage input) / 250 $\Omega$ (current input)   |
| Y2                   | Open collector output terminal, the corresponding common ground output terminal is CME<br>External voltage range:0~24V<br>Output current range:0~50mA |
| CME2                 | Open collector output common terminal   |
| AO2                  | Analog quantity output terminal<br>Output range:0~10V/0~20mA(select voltage or current output by J2)  |
| RS485+<br>RS485-     | RS485 serial communication  |
| RO3A<br>RO3B<br>RO3C | RO3 relay output:RO3A common,RO3B NC,RO3C NO<br>Contact capacity:AC250V/3A,DC30V/1A   |

**Jumper**

| Jumper name | Usage and instruction   |
|-------------|---|
| J1          | Switch between 0~10V/0~20mA input. Short-connect 1(V) and 2(GND) as the voltage input and short-connect 2(GND) and 3(I) as the current input. |
| J2          | Switch between 0~10V/0~20mA input. Short-connect 1(V) and 2(GND) as the voltage input and short-connect 2(GND) and 3(I) as the current input. |
| S1          | Communication terminal setting of RS485<br>ON: Apply the terminal<br>OFF: Do not apply the terminal   |

**7.2.2 Description of dimension and terminal compositor**

(1) Dimension of I/O extension card and sketch map for CHV180

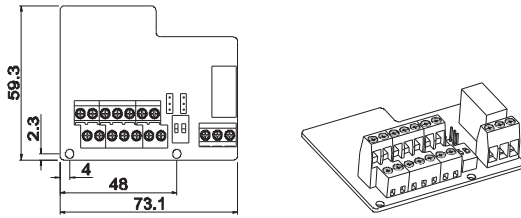
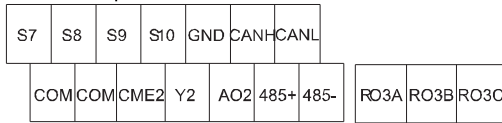

Figure 7.5 Dimension of I/O extension card.

(2) Sketch map of terminal compositor



**7.2.3 Installation of I/O extension card for CHV180**

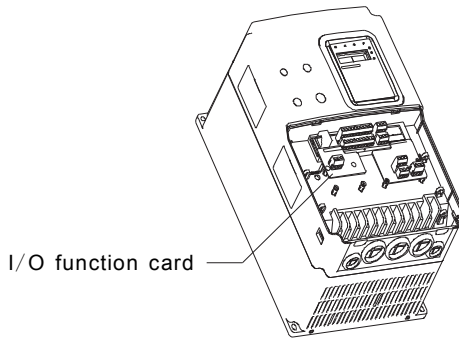

Figure 7.6 Installation of of I/O extension card and PG card.

**7.3 Description of asynchronous motor PG card**

**7.3.1 Model and specifications**

7.3.1.1 The asynchronous PG card of CHV100 series inverters is PN000PGWX, below is the specification table:

| Terminal name | Specification   |
|---------------|---|
| 12V and COM1  | Power supply of the encoder<br>Max. output current: 300mA |

| Terminal name                    | Specification   |
|----------------------------------|---|
| TERA+<br>TERA-<br>TERB+<br>TERB- | Input channel of the encoder signal<br>Voltage range: 12~15V<br>Response speed: 0~80kHz |
| TER-OA<br>TER-OB                 | Output frequency: 0~80kHz<br>Output impedance: 30Ω<br>Frequency range: 1~256            |

### 7.3.1.2 Dimensions and Installation of asynchronous motor PG card

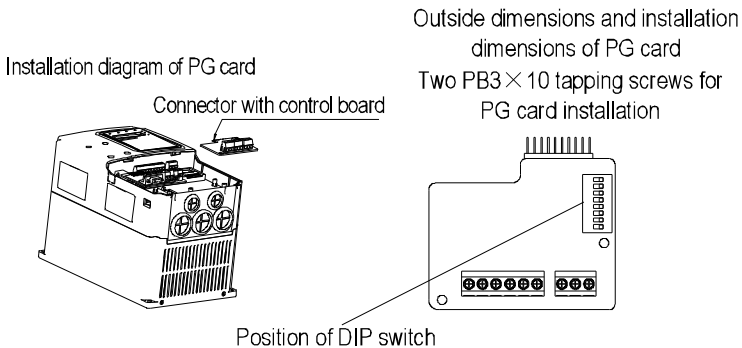

Figure 7.7 Installation and dimensions of PG card.

**Note: Asynchronous PG card can be plugged in the below of the control board CN9. Synchronous PG card can be plugged in CN9.**

### 7.3.2 Operating Instructions of asynchronous motor PG card

#### 7.3.2.1 Functions

##### Functions

When the user selects PG vector control, it is necessary to select PG Card. The function of PG card includes 2 ways of processing circuit for orthogonal encoder signal and it can receive differential, open collector and push-pull output signal and the power supply of the encoder (+12V); it can also output frequency division for the encoder signal (the output is 2 ways of orthogonal open collector signal), so the user can select according to the actual use.

7.3.2.2 Terminals and DIP

There are 9 wiring terminals in asynchronous PG card:

|      |      |       |       |       |       |        |        |      |
|------|------|-------|-------|-------|-------|--------|--------|------|
| +12V | COM1 | TERA+ | TERA- | TERB+ | TERB- | TER-OA | TER-OB | COM1 |
|------|------|-------|-------|-------|-------|--------|--------|------|

Figure 7.8 Wiring terminals in asynchronous PG card.

Among them, +12V and COM1 are the power supply output for the encoder; TERA+, TERA-, TERB+ and TERB- are the input terminal for the encoder; TER-OA, TER-OB and COM1 are the output terminal for frequency division signal and there is no PE in the internal of the card, so the user can ground by themselves during use.

The frequency coefficient of asynchronous PG card is determined by the DIP switch on the card. There are 8 switches and the frequency coefficient is decided by the shown binary figures that are added by 1. "1" on the switch s the low bit and "8" is the high bit. When the DIP is switched to ON, the bit is valid, reverse it is "0".

Frequency division coefficient:

| Decimal Digit | Binary Digit | Frequency Division Factor |
|---------------|--------------|---------------------------|
| 0             | 00000000     | 1                         |
| 1             | 00000001     | 2                         |
| 2             | 00000010     | 3                         |
| ...           | ...          | ...                       |
| m             | ...          | m+1                       |
| 255           | 11111111     | 256                       |

7.3.2.3 Wiring Diagram

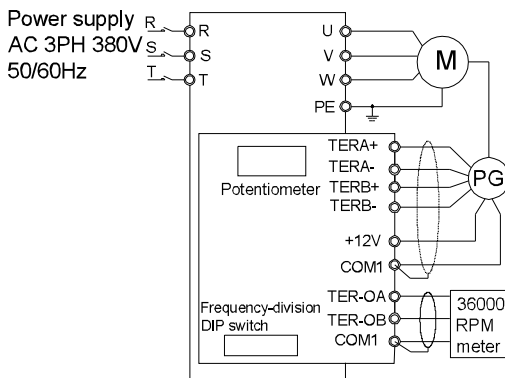

Figure 7.8 PG Card Wiring Diagram.

**7.3.2.4 Wiring precautions**

The signal wire of the PG card should be routed separately from the power lines.

Please select the shield cables as the PG signal wire for the avoidance of encoder signal.

The shield layer of the encoder cables should be founded with one end (for example, the PE end of the inverter) for the avoidance of the signal interference.

If the frequency division output of the PG card is connected with the user power supply, the voltage is less than 24V, otherwise, the PG card may be damaged.

**7.3.3 Application Connection**

(1) Wiring Diagram of Differential Output Coder

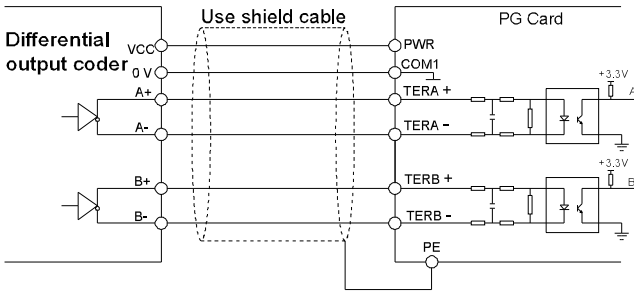

Figure 7.9 Wiring Diagram of Differential Output Coder.

(2) Wiring Diagram of Open Collector Output Coder

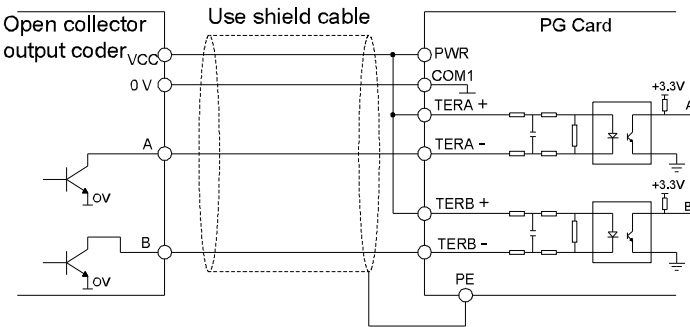

Figure 7.10 Wiring Diagram of Open Collector Output Coder.

(3) Wiring Diagram of Push-pull Output Coder

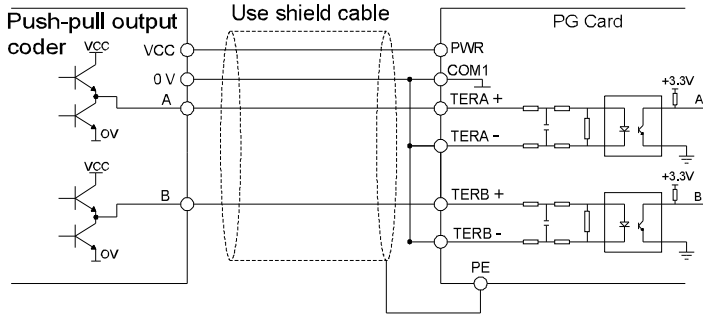

Figure 7.11 Wiring Diagram of Push-pull Output Coder.

(4) Wiring Diagram of PG Card Frequency-division Output

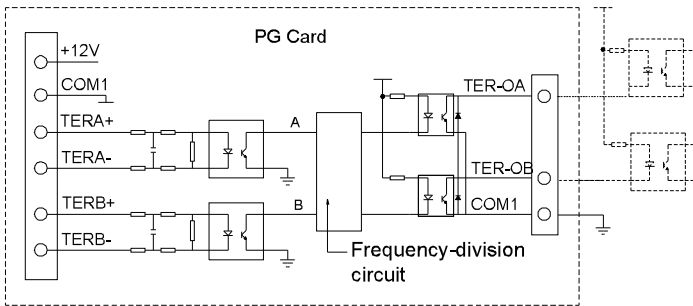

Figure 7.12 Wiring Diagram of PG Card Frequency-division Output.

### 7.4 Description of PG card for synchronous motor

#### 7.4.1 Model and specifications

The synchronous PG card is compatible with UVW encoder and SIN encoder. There are two types of model:

| Model of PG card               | CHV180-SY-PG-UVW                   | CHV180-SY-PG-SIN                   |
|--------------------------------|------------------------------------|------------------------------------|
| The supported encoder types    | UVW encoder                        | SIN/COS encoder                    |
| Frequency division coefficient | 1~256(with dial switching)         | 1(without dial switching)          |
| Encoder voltage                | 5V/±5%                             | 5V/±5%                             |
| Signal port of PG              | Same with the description of 7.4.3 | Same with the description of 7.4.3 |



Users select the card according to the actual requirement.

**7.4.2 Dimensions and schematic diagram of UVW type synchronous PG**

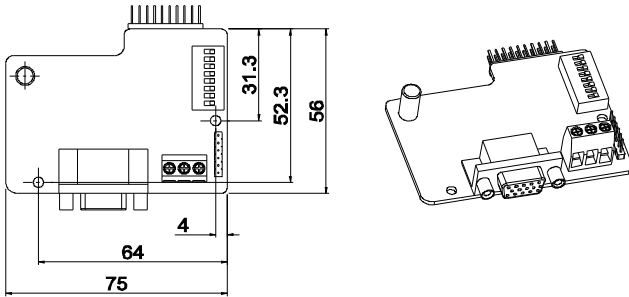

Figure 7.13 Dimensions and schematic diagram of UVW type synchronous PG

Note:

- 1) The installation position and method of synchronous motor PG card are the same as that of the asynchronous motor PG card, but the contact pin has two lines, the contact pin of asynchronous motor PG card is only one line(the below line of CN9).
- 2) The dimension of SIN/COS type synchronous PG is consistent with UVW type PG card only without dial switching for frequency division.
- 3) The PG card of asynchronous motor is used in all of CHV series inverters, but the PG card of synchronous motor is only used to CHV180 inverter. When user is using the synchronous tractor, they must select the PG card of synchronous motor.

**7.4.3 Description of Terminals and Dial Switch**

The PG card has one signal wire port and 3 user terminal (output signal of frequency division) shown as Figure 7.14:

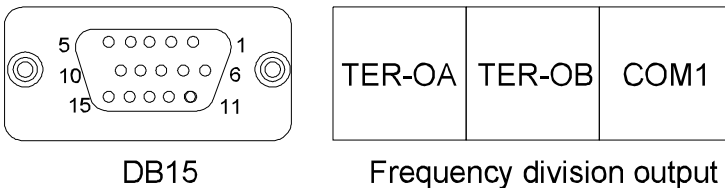

Figure 7.14 The PG card wire port and wire terminals.

TER-OA, TER-OB and COM1 are the signal terminals of frequency division output.

**Note: PE terminal in PG card are not grounded to the earth, so users can grounding it by themselves.**

DB15 is the port of the encoder input signal. The sequence of the ports signal is as below:

| Port | SIN/COS | UVW   |
|------|---------|-------|
| 8    | A       | A     |
| 3    | A-      | A-    |
| 9    | B       | B     |
| 4    | B-      | B-    |
| 15   | R       | Z     |
| 14   | R-      | Z-    |
| 6    | C       | U     |
| 1    | C-      | U-    |
| 7    | D       | V     |
| 2    | D-      | V-    |
| 12   | 5V      | 5V    |
| 13   | 0V      | 0V    |
| 10   | Empty   | W     |
| 5    | Empty   | W-    |
| 11   | Empty   | Empty |

When using the synchronous PG card, it is necessary to insert the connecting wire of SIN/COS or UWW whose signal array is corresponding with PG card into DB15 of PG card.

The frequency division coefficient is determined by the dial switch on the card. The dial switch consists of 8 bits. The frequency division is decided by the value of the binary digits (at dial switch) plus 1. The bit marked as "1" on the DIP switch is the lower binary bit, while "8" is the higher binary bit. When the dial switch is switched to ON, the bit is valid, indicating "1"; otherwise, it is invalid, and it is indicating "0".

Frequency division coefficients are shown in the table below:

| Decimal Digit | Binary Digit | Frequency Division Coefficients |
|---------------|--------------|---------------------------------|
| 0             | 00000000     | 1                               |
| 1             | 00000001     | 2                               |
| 2             | 00000010     | 3                               |

| <b>Decimal Digit</b> | <b>Binary Digit</b> | <b>Frequency Division Coefficients</b> |
|----------------------|---------------------|--|
| 0                    | 00000000            | 1                                      |
| 1                    | 00000001            | 2                                      |
| 2                    | 00000010            | 3                                      |
| ...                  | ...                 | ...                                    |
| m                    | ...                 | m+1                                    |
| 255                  | 11111111            | 256                                    |

## 8. Trouble shooting

### 8.1 Fault and trouble shooting

The inverter has perfect functions to carry out effect protection; meanwhile the performance of equipment can be full played. Please refer to the following table to analyze the possible fault and find out the reason for exclusion. When the equipment is damaged, please contact local agent, service center or manufacturers for the solution.

| Fault Code | Fault Type                               | Reason   | Solution   |
|------------|--|--|--|
| OUT1       | IGBT Ph-U fault                          | <ol style="list-style-type: none"> <li>1. Acc/Dec time is too short.</li> <li>2. IGBT module fault.</li> <li>3. Malfunction caused by interference.</li> <li>4. Grounding is not properly.</li> </ol>  | <ol style="list-style-type: none"> <li>1. Increase Acc/Dec time.</li> <li>2. Ask for support.</li> <li>3. Inspect external equipment and eliminate interference.</li> </ol>  |
| OUT2       | IGBT Ph-V fault                          |  |  |
| OUT3       | IGBT Ph-W fault                          |  |  |
| OC1        | Over-current when acceleration           | <ol style="list-style-type: none"> <li>1. Acc time is too short.</li> <li>2. Voltage is too low.</li> <li>3. Power of the inverter is too low.</li> </ol>  | <ol style="list-style-type: none"> <li>1. Increase Acc time.</li> <li>2. Check the input power</li> <li>3. Select bigger capacity inverter.</li> </ol>   |
| OC2        | Over-current when deceleration           | <ol style="list-style-type: none"> <li>1. Dec time is too short.</li> <li>2. Inertia torque of the load is big.</li> <li>3. Power of the inverter is too low.</li> </ol>   | <ol style="list-style-type: none"> <li>1. Increase Dec time.</li> <li>2. Add proper braking kits.</li> <li>3. Select bigger capacity inverter.</li> </ol>  |
| OC3        | Over-current when constant speed running | <ol style="list-style-type: none"> <li>1. The load transients or is abnormal.</li> <li>2. Voltage is too low</li> <li>3. Power of the inverter is too low.</li> <li>4. The close loop runs at a high speed or offline and fault to the encoding disk.</li> </ol> | <ol style="list-style-type: none"> <li>1. Check the load and reduce the transients.</li> <li>2. Check the input power.</li> <li>3. Select bigger capacity inverter.</li> <li>4. Check the encoding disk and wiring.</li> </ol> |

|     |  |  |  |
|-----|--|--|--|
| OV1 | Over-voltage when acceleration           | 1. Input voltage is abnormal<br>2. After sudden power off, restart the rotating motor.   | 1. Check the input power.<br>2. Avoid restarting after stopping.   |
| OV2 | Over-voltage when deceleration           | 1. Dec time is too short.<br>2. Load inertia is big.<br>3. Input voltage is abnormal.  | 1. Increase Dec time.<br>2. Increase proper braking kits.<br>3. Check the input power.   |
| OV3 | Over-voltage when constant speed running | 1. Input voltage changes abnormally.<br>2. Load inertia is big.  | 1. Install input reactor.<br>2. Add proper braking kits.   |
| UV  | DC bus Under-voltage                     | 1. Voltage is too low.   | Inspect the input power supply.  |
| OL1 | Motor overload                           | 1. The voltage is too low.<br>2. Improper rated current of the motor.<br>3. Motor stalling or the load transits too much.<br>4. Open loop vector control, reverse direction of the encoding disk or run at low speed for a long time.<br>5. Motor drive heavy load at low speed for a long time. | 1. Check the input power.<br>2. Reset the rated current of the motor.<br>3. Check the load and adjust the torque boost.<br>4. Adjust the direction of the encoding disk signal.<br>5. Select proper motor. |
| OL2 | Inverter overload                        | 1. Acc time is too short.<br>2. Restart the rotating motor.<br>3. Input voltage is too low.<br>4. The load is too heavy.<br>5. Close loop vector.<br>Control reverse direction of  | 1. Increase Acc time or select bigger capacity inverter.<br>2. Avoid restarting after stopping.<br>3. Select bigger capacity inverter.   |

|     |                      |  |  |
|-----|----------------------|--|--|
|     |                      | the encoding disk or run at low speed for a long time.   | 4. Adjust the direction of the encoding disk.  |
| SPI | Input phase failure  | Input phase failure of R,S,T.  | Check the wiring, installation and power supply.   |
| SPO | Output phase failure | 1. U, V and W phase loss output.<br>2. If the motor is not connected, the pre-exciting can not be completed.   | Check the wiring, motor and cable.   |
| OH1 | Rectify overheat     | 1. Sudden overcurrent to the inverter.<br>2. The output phase is short circuited.<br>3. Ventilation duct or the fan is damaged.<br>4. Ambient temperature is too high.<br>5. The wiring of the control board or the plug-in is loose.<br>6. The assistant circuit is damaged and | 1. Refer to the overcurrent solution.<br>2. Reconfiguration.<br>3. Clear out the ventilation duct and change the fan.<br>4. Reduce the ambient temperature.<br>5. Check and rewire.<br>6. Ask for support.<br>7. Ask for support.<br>8. Ask for support. |
| OH2 | IGBT overheat        | undervoltage to the drive voltage.<br>7. Direct bridge arm of the power module.<br>8. The control board is abnormal.   |  |
| EF  | External fault       | SI: External fault input terminal take effect.   | Inspect external equipment.  |

|      |                         |  |   |
|------|-------------------------|--|---|
| CE   | Communication fault     | <ol style="list-style-type: none"> <li>1. Improper baud rate setting.</li> <li>2. Receive wrong data.</li> <li>3. Communication is interrupted for long time.</li> </ol>   | <ol style="list-style-type: none"> <li>1. Select proper baud rate.</li> <li>2. Press STOP/RST to reset and ask for support.</li> <li>3. Check communication devices and signals.</li> </ol>   |
| ITE  | Current detection fault | <ol style="list-style-type: none"> <li>1. Wires or connectors of control board are loose.</li> <li>2. The assistant circuit is damaged.</li> <li>3. Hall sensor is damaged.</li> <li>4. Amplifying circuit is abnormal.</li> </ol>   | <ol style="list-style-type: none"> <li>1. Check the connector and rewire.</li> <li>2. Ask for support</li> <li>3. Ask for support</li> <li>4. Ask for support</li> </ol>  |
| TE   | Autotuning fault        | <ol style="list-style-type: none"> <li>1. The capacity of the motor is not compatible with that of the inverter.</li> <li>2. Improper setting of motor rated parameters.</li> <li>3. Large offset between the parameters in the autotuning and the standard parameters.</li> <li>4. Overtime of autotuning.</li> </ol> | <ol style="list-style-type: none"> <li>1. Change the model of the inverter</li> <li>2. Set the rated parameters according to the nameplate of the motor</li> <li>3. Empty the motor and reidentify</li> <li>4. Check motor's wiring and the parameters setting</li> </ol> |
| PCE  | Encoder fault           | <ol style="list-style-type: none"> <li>1. Signal wire of encoder was broken.</li> <li>2. Encoder was damaged.</li> </ol>   | <ol style="list-style-type: none"> <li>1. Inspect encoder connection.</li> <li>2. Inspect whether the encoder output signal or not.</li> </ol>  |
| PCDE | Encoder reverse fault   | Encoder signal wire was connected wrong.   | Adjust encoder wiring.  |

|       |                                  |  |  |
|-------|----------------------------------|--|--|
| PPCE  | Detection fault of magnetic pole | The autotuning detection fault of magnetic pole.   | 1. Inspect motor parameters.<br>2. Input correct parameters of motor and re-autotuning.          |
| EEP   | EEPROM fault                     | 1. Read/Write fault of control parameters.<br>2. EEPROM damage.  | 1. Press STOP/RST to reset.<br>2. Ask for support.   |
| PIDE  | PID feedback fault               | 1. PID feedback disconnected.<br>2. PID feedback source disappears.  | 1. Inspect PID feedback signal wire.<br>2. Inspect PID feedback source.                          |
| bCE   | Braking unit fault               | 1. Braking circuit failure or brake tube damaged.<br>2. Too low resistor of externally connected braking resistor. | 1. Inspect braking unit, replace braking tube.<br>2. Increase braking resistor.                  |
| -END- | Trial time reached               | Trial time which determined by factory reached.  | Contact supplier and ask for support.  |
| LCD-E | LCD disconnected                 | 1. LCD disconnected.<br>2. Material broken during tension control.   | 1. Press STOP/RST to reset, connect LCD then download or upload parameter.<br>2. Check material. |
| FAE   | Holding brake fault              | Fault of brake feedback.   | Check the elevator control system.   |
| TbE   | Contactors feedback fault        | Contactors feedback is fault.  | Check the elevator control system.   |
| dEV   | Too large speed deviation        | The protection functions of too large speed deviation.   | Check the wiring of encoder is right, and whether the deviation is too small.                    |



## 8.2 Common faults and solutions

Inverter may have following faults or malfunctions during operation, please refer to the following solutions.

### No display after power on:

- Inspect whether the voltage of power supply is the same as the inverter rated voltage or not with multi-meter. If the power supply has problem, inspect and solve it.
- Inspect whether the three-phase rectify bridge is in good condition or not. If the rectification bridge is burst out, ask for support.
- Check the CHARGE light. If the light is off, the fault is mainly in the rectify bridge or the buffer resistor. If the light is on, the fault may be lies in the switching power supply. Please ask for support.

### Power supply air switch trips off when power on:

- Inspect whether the input power supply is grounded or short circuit. Please solve the problem.
- Inspect whether the rectify bridge has been burnt or not. If it is damaged, ask for support.

### Motor doesn't move after inverter running:

- Inspect if there is balanced three-phase output among U, V, and W. If yes, then motor could be damaged, or mechanically locked. Please solve it.
- If the output is unbalanced or lost, the inverter drive board or the output module may be damaged, ask for support.

### The inverter displays normally when power on, but switch at the input side trips when running:

- Inspect whether the output side of inverter is short circuit. If yes, ask for support.
- Inspect whether ground fault exists. If yes, solve it.
- If trip happens occasionally and the distance between motor and inverter is too far, it is recommended to install output AC reactor.

## 9. Maintenance



- Maintenance must be performed according to designated maintenance methods.
- Only qualified technicians are allowed to carry out the **maintenance**.
- Disconnect the power supply before maintenance. Wait for 10 minutes before maintenance.
- Do not touch the components or devices on PCB board directly. Otherwise inverter may be damaged by electrostatic.
- Check to ensure the tightness of the screws after the maintenance.

### 9.1 Daily maintenance

Daily maintenance should be performed for the avoidance of the fault and insurance of the normal operation and long usage. See the following table for the detailed maintenance:

| Items                | Instructions   |
|----------------------|--|
| Temperature/Humidity | Check to ensure the ambient temperature is among 0°C~50°C and the humidity is among 20~90%.  |
| Oil fog and dust     | Check to ensure there is no oil fog, dust and condensation in the inverter.                  |
| The inverter         | Check to ensure that there is abnormal heating and vibration in the inverter.                |
| The fan              | Check to ensure the fan works normally and there is no foreign objection in the inverter.    |
| Input power supply   | Check to ensure the voltage and frequency of the input power supply is in the allowed range. |
| The motor            | Check to ensure there is no abnormal vibration, heating, noise and phase loss on the motor.  |

### 9.2 Periodic maintenance

The user has to check the inverter periodically (within half year) for the avoidance of fault and stable and longterm high-performance running. See the following table for the detailed check:

| Items                               | Instructions  | Method  |
|-------------------------------------|---|---|
| The screws of the external terminal | Check the screws are loose or not.  | Tight the screw driver/sleeve.                                |
| PCB board                           | Dust and dirtiness.   | Use dry and compressed air to clean the dirtiness completely. |
| The fan                             | The accumulative time of abnormal noise and vibration is over 20 thousand hours.                              | 1. Clean the foreign objections.<br>2. Chang the fan.         |
| Electrolytic capacitors             | Check the color changes or not and there is peculiar smell.   | Change the electrolytic capacitor.                            |
| Radiator                            | Dust and dirtiness.   | Use dry and compressed air to clean the dirtiness completely. |
| Power component                     | Dust and dirtiness.   | Use dry and compressed air to clean the dirtiness completely. |
| Connection wires                    | Check to ensure the internal connection wires, plug-in parts and the plug of the extension card is available. | The screw driver and hands.                                   |

### 9.3 Replacement of wearing parts

Fans and electrolytic capacitors are wearing part; please change the wearing parts periodically for a longterm, safe and smooth operation. The replacement periods of the wearing parts are as follows:

- ◆Fan: Should be changed after 20,000 hours of utilization;
- ◆Electrolytic Capacitor: Should be changed after 30,000~40, 000 hours of utilization.

## 10. Communication protocol

### 10.1 Interfaces

RS485: asynchronous, half-duplex.

Default: 8-E-1, 19200bps. See Group PC parameter settings.

### 10.2 Communication modes

(1) The protocol is Modbus protocol. Besides the common register Read/Write operation, it is supplemented with commands of parameters management.

(2) The drive is a slave in the network. It communicates in 'point to point' master-slave mode. It will not respond to the command sent by the master via broadcast address.

(3) In the case of multi-drive communication or long-distance transmission, connecting a 100~120Ω resistor in parallel with the master signal line will help to enhance the immunity to interference.

### 10.3 Protocol format

Modbus protocol supports both RTU and ASCII mode. The frame format is illustrated as follows:

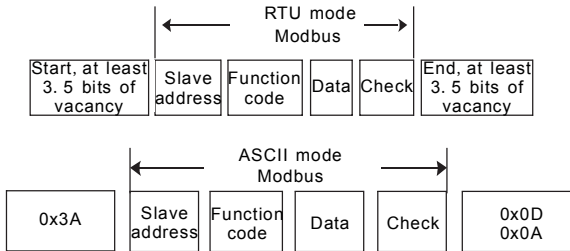

Modbus adopts "Big Endian" representation for data frame. This means that when a numerical quantity larger than a byte is transmitted, the most significant byte is sent first.

#### RTU mode

In RTU mode, the Modbus minimum idle time between frames should be no less than 3.5 bytes. The checksum adopts CRC-16 method. All data except checksum itself sent will be counted into the calculation. Please refer to section: CRC Check for more information. Note that at least 3.5 bytes of Modbus idle time should be kept and the start and end idle time need not be summed up to it.

The table below shows the data frame of reading parameter 002 from slave node

address 1.

| Node addr. | Command | Data addr. |      | Read No. |      | CRC  |      |
|------------|---------|------------|------|----------|------|------|------|
| 0x01       | 0x03    | 0x00       | 0x02 | 0x00     | 0x01 | 0x25 | 0xCA |

The table below shows the reply frame from slave node address 1.

| Node addr. | Command | Bytes No. | Data |      | CRC  |      |
|------------|---------|-----------|------|------|------|------|
| 0x01       | 0x03    | 0x02      | 0x00 | 0x00 | 0xB8 | 0x44 |

**ASCII mode**

In ASCII mode, the frame head is “0x3A”, and default frame tail is “0x0D” or “0x0A”. The frame tail can also be configured by users. Except frame head and tail, other bytes will be sent as two ASCII characters, first sending higher nibble and then lower nibble. The data have 7/8 bits. “A”~“F” corresponds to the ASCII code of respective capital letter. LRC check is used. LRC is calculated by adding all the successive bytes of the message except the head and tail, discarding any carriers, and then two’s complementing the result.

Example of Modbus data frame in ASCII mode:

The command frame of writing 0x0003 into address “0x1000” of slave node address 1 is shown in the table below:

LRC checksum = the complement of (01+06+10+00+0x00+0x03) = 0xE5

|               | Frame head |    | Node addr. |    | Command |    | Data addr. |    |    |    |
|---------------|------------|----|------------|----|---------|----|------------|----|----|----|
| Code          |            |    | 0          | 1  | 0       | 6  | 1          | 0  | 0  | 0  |
| ASCII         | 3A         |    | 30         | 31 | 30      | 36 | 31         | 30 | 30 | 30 |
| Data to write |            |    |            |    | LRC     |    | Frame tail |    |    |    |
| 0             | 0          | 0  | 3          |    | E       | 5  | CR         |    | LF |    |
| 30            | 30         | 30 | 33         |    | 45      | 35 | 0D         |    | 0A |    |

**10.4 Protocol function**

Different respond delay can be set through drive’s parameters to adapt to different needs. For RTU mode, the respond delay should be no less than 3.5 bytes interval, and for ASCII mode, no less than 1ms.

The main function of Modbus is to read and write parameters. The Modbus protocol supports the following commands:

|      |  |
|------|--|
| 0x03 | Read inverter’s function parameter and state parameters          |
| 0x06 | Write single function parameter or command parameter to inverter |

All drive’s function parameters, control and state parameters are mapped to Modbus R/W data address.

The data address of control and state parameters please refer to the following table.

| Parameter Description                   | Address       | Meaning of value  | R/W Feature |
|---|---------------|---|-------------|
| Control command                         | 1000H         | 0001H: Up running   | W/R         |
|   |               | 0002H: Down running   |             |
|   |               | 0003H: Up running overhaul  |             |
|   |               | 0004H: Down running overhaul  |             |
|   |               | 0005H: Stop   |             |
|   |               | 0006H: Coast to stop  |             |
|   |               | 0007H: Reset fault  |             |
|   |               | 0008H: overhauling ceased   |             |
| Inverter state                          | 1001H         | 0001H: Up running   | R           |
|   |               | 0002H: Down running   |             |
|   |               | 0003H: Standby  |             |
|   |               | 0004H: Fault  |             |
| Communication setting                   | 2000H         | Communication Setting Range (-10000~10000)<br>Note: the communication setting is the percentage of the relative value (-100.00%~100.00%). If it is set as frequency source, the value is the percentage of the maximum frequency (P0.04). | W/R         |
| Virtual terminal input function setting | 2001H         | Reserved  | W/R         |
| State parameters                        | 3000H         | Output speed  | R           |
|   | 3001H         | Reference speed   | R           |
|   | 3002H         | DC Bus voltage  | R           |
|   | 3003H         | Output voltage  | R           |
|   | 3004H         | Output current  | R           |
|   | 3005H         | Running frequency   | R           |
|   | 3006H         | Rotation speed  | R           |
|   | 3007H         | Output power  | R           |
| 3008H                                   | Output torque | R   |             |

| Parameter Description                         | Address          | Meaning of value  | R/W Feature |
|---|------------------|---|-------------|
|   | 3009H            | Input terminal state  | R           |
|   | 300AH            | Output terminal state.  | R           |
|   | 300BH            | Input of AI1  | R           |
|   | 300CH            | Input of AI2  | R           |
|   | 300DH            | Torque compensation   | R           |
|   | 300EH            | Pole position   | R           |
|   | 300FH ~<br>3014H | Reserved  | R           |
|   | 3015H            | Torque direction<br>(0: forward, 1: reverse)  | R           |
|   | 3016H            | Device code   | R           |
| Parameter lock<br>password check address      | 4000H            | ****  | R           |
| Parameter lock<br>password command<br>address | 4001H            | 55AAH   | R           |
| Fault info address                            | 5000H            | This address stores the fault<br>type of inverter. The meaning of<br>each value is same as P7.15. | R           |

The above shows the format of the frame. Now we will introduce the Modbus command and data structure in details, which is called protocol data unit for simplicity. Also MSB stands for the most significant byte and LSB stands for the least significant byte for the same reason. The description below is data format in RTU mode. The length of data unit in ASCII mode should be doubled.

Protocol data unit format of reading parameters:

Request format:

| Protocol data unit | Data length(bytes) | Range         |
|--------------------|--------------------|---------------|
| Command            | 1                  | 0x03          |
| Data Address       | 2                  | 0~0xFFFF      |
| Read number        | 2                  | 0x0001~0x0010 |

Reply format (success):

| Protocol data unit   | Data length(bytes) | Range          |
|----------------------|--------------------|----------------|
| Command              | 1                  | 0x03           |
| Returned byte number | 2                  | 2* Read number |
| Content              | 2* Read number     |                |

If the command is reading the type of inverter (data address 0x3016), the content value in reply message is the device code:

The high 8 bit of device code is the type of the inverter, and the low 8 bit of device code is the sub type of inverter.

For details, please refer to the following table:

| High byte | Meaning | Low byte | Meaning                 |
|-----------|---------|----------|-------------------------|
| 00        | CHV     | 01       | Universal type          |
|           |         | 02       | For water supply        |
|           |         | 03       | Middle frequency 1500HZ |
|           |         | 04       | Middle frequency 3000HZ |
| 01        | CHE     | 01       | Universal type          |
|           |         | 02       | Middle frequency 1500HZ |
| 02        | CHF     | 01       | Universal type          |

If the operation fails, the inverter will reply a message formed by failure command and error code. The failure command is (Command+0x80). The error code indicates the reason of the error; see the table below.

| Value | Name                  | Mean  |
|-------|-----------------------|---|
| 01H   | Illegal command       | The command from master can not be executed. The reason maybe:<br>1. This command is only for new version and this version can not realize.<br>2. Slave is in fault state and can not execute it.             |
| 02H   | Illegal data address. | Some of the operation addresses are invalid or not allowed to access.   |
| 03H   | Illegal value         | When there are invalid data in the message framed received by slave.<br>Note: This error code does not indicate the data value to write exceed the range, but indicate the message frame is an illegal frame. |
| 06H   | Slave busy            | Inverter is busy(EEPROM is storing)   |
| 10H   | Password              | The password written to the password check address is not   |



| Value | Name                 | Mean  |
|-------|----------------------|---|
|       | error                | same as the password set by P7.00.  |
| 11H   | Check error          | The CRC (RTU mode) or LRC (ASCII mode) check not passed.  |
| 12H   | Written not allowed. | It only happen in write command, the reason maybe:<br>1. The data to write exceed the range of according parameter.<br>2. The parameter should not be modified now.<br>3. The terminal has already been used. |
| 13H   | System locked        | When password protection take effect and user does not unlock it, write/read the function parameter will return this error.   |

Protocol data unit format of writing single parameter:

Request format:

| Protocol data unit | Data length(bytes) | Range    |
|--------------------|--------------------|----------|
| Command            | 1                  | 0x06     |
| Data Address       | 2                  | 0~0xFFFF |
| Write Content      | 2                  | 0~0xFFFF |

Reply format (success):

| Protocol data unit | Data length(bytes) | Range    |
|--------------------|--------------------|----------|
| Command            | 1                  | 0x06     |
| Data Address       | 2                  | 0~0xFFFF |
| Write Content      | 2                  | 0~0xFFFF |

If the operation fails, the inverter will reply a message formed by failure command and error code. The failure command is (Command+0x80). The error code indicates the reason of the error; see table 1.

## 10.5 Note

10.5.1 Between frames, the span should not less than 3.5 bytes interval, otherwise, the message will be discarded.

10.5.2 Be cautious to modify the parameters of PC group through communication, otherwise may cause the communication interrupted.

10.5.3 In the same frame, if the span between two .near bytes more than 1.5 bytes interval, the behind bytes will be assumed as the start of next message so that communication will failure.

## 10.6 CRC check

For higher speed, CRC-16 uses tables. The following are C language source code for CRC-16.

```
unsigned int crc_cal_value(unsigned char *data_value,unsigned char data_length)
{
int i;
unsigned int crc_value=0xffff;
while(data_length--)
{
  crc_value^=*data_value++;
  for(i=0;i<8;i++)
  {
if(crc_value&0x0001)crc_value=(crc_value>>1)^0xa001;
    else crc_value=crc_value>>1;
  }
}
return(crc_value);
}
```

## 10.7 Example

### 10.7.1 RTU mode read 2 data from 0004H

The request command is:

|                            |  |
|----------------------------|--|
| START                      | T1-T2-T3-T4 (transmission time of 3.5 bytes) |
| Node address               | 01H  |
| Command                    | 03H  |
| High byte of start address | 00H  |
| Low byte of start address  | 04H  |
| High byte of data number   | 00H  |
| Low byte of data number    | 02H  |
| Low byte of CRC            | 85H  |
| High byte of CRC           | CAH  |
| END                        | T1-T2-T3-T4 (transmission time of 3.5 bytes) |

The reply is :

|                      |  |
|----------------------|--|
| START                | T1-T2-T3-T4 (transmission time of 3.5 bytes) |
| Node address         | 01H  |
| Command              | 03H  |
| Returned byte number | 04H  |

|                      |  |
|----------------------|--|
| Higher byte of 0004H | 13H  |
| Low byte of 0004H    | 88H  |
| High byte of 0005H   | 05H  |
| Low byte of 0005H    | DCH  |
| Low byte of CRC      | 7CH  |
| High byte of CRC     | 54H  |
| END                  | T1-T2-T3-T4 (transmission time of 3.5 bytes) |

**10.7.2 ASCII mode, read 2 data from 0004H:**

The request command is:

|                            |     |
|----------------------------|-----|
| START                      | ':' |
| Node address               | '0' |
|                            | '1' |
| Command                    | '0' |
|                            | '3' |
| High byte of start address | '0' |
|                            | '0' |
| Low byte of start address  | '0' |
|                            | '4' |
| High byte of data number   | '0' |
|                            | '0' |
| Low byte of data number    | '0' |
|                            | '2' |
| LRC CHK Hi                 | 'F' |
| LRC CHK Lo                 | '6' |
| END Lo                     | CR  |
| END Hi                     | LF  |

The reply is

|                      |     |
|----------------------|-----|
| START                | ':' |
| Node address         | '0' |
|                      | '1' |
| Command              | '0' |
|                      | '3' |
| Returned byte number | '0' |
|                      | '4' |

|                      |     |
|----------------------|-----|
| Higher byte of 0004H | '1' |
|                      | '3' |
| Low byte of 0004H    | '8' |
|                      | '8' |
| High byte of 0005H   | '0' |
|                      | '5' |
| Low byte of 0005H    | 'D' |
|                      | 'C' |
| LRC CHK Lo           | '7' |
| LRC CHK Hi           | 'C' |
| END Lo               | CR  |
| END Hi               | LF  |

### 10.7.3 RTU mode, write 5000(1388H) into address 0008H, slave node address 02.

The request command is:

|                            |  |
|----------------------------|--|
| START                      | T1-T2-T3-T4 (transmission time of 3.5 bytes) |
| Node address               | 02H  |
| Command                    | 06H  |
| High byte of data address  | 00H  |
| Low byte of data address   | 04H  |
| High byte of write content | 13H  |
| Low byte of write content  | 88H  |
| Low byte of CRC            | C5H  |
| High byte of CRC           | 6EH  |
| END                        | T1-T2-T3-T4 (transmission time of 3.5 bytes) |

The reply command is:

|                            |  |
|----------------------------|--|
| START                      | T1-T2-T3-T4 (transmission time of 3.5 bytes) |
| Node address               | 02H  |
| Command                    | 06H  |
| High byte of data address  | 00H  |
| Low byte of data address   | 04H  |
| High byte of write content | 13H  |
| Low byte of write content  | 88H  |
| Low byte of CRC            | C5H  |
| High byte of CRC           | 6EH  |

|     |  |
|-----|--|
| END | T1-T2-T3-T4 (transmission time of 3.5 bytes) |
|-----|--|

**10.7.4 ASCII mode, write 5000(1388H) into address 0008H, slave node address 02.**

The request command is:

|                            |     |
|----------------------------|-----|
| START                      | ‘:’ |
| Node address               | ‘0’ |
|                            | ‘2’ |
| Command                    | ‘0’ |
|                            | ‘6’ |
| High byte of data address  | ‘0’ |
|                            | ‘0’ |
| Low byte of data address   | ‘0’ |
|                            | ‘4’ |
| High byte of write content | ‘1’ |
|                            | ‘3’ |
| Low byte of write content  | ‘8’ |
|                            | ‘8’ |
| LRC CHK Hi                 | ‘5’ |
| LRC CHK Lo                 | ‘9’ |
| END Lo                     | CR  |
| END Hi                     | LF  |

The reply command is:

|                            |     |
|----------------------------|-----|
| START                      | ‘:’ |
| Node address               | ‘0’ |
|                            | ‘2’ |
| Command                    | ‘0’ |
|                            | ‘6’ |
| High byte of data address  | ‘0’ |
|                            | ‘0’ |
| Low byte of data address   | ‘0’ |
|                            | ‘4’ |
| High byte of write content | ‘1’ |
|                            | ‘3’ |
| Low byte of write content  | ‘8’ |

|            |     |
|------------|-----|
|            | '8' |
| LRC CHK Hi | '5' |
| LRC CHK Lo | '9' |
| END Hi     | CR  |
| END Lo     | LF  |

**10.7.5 Command code 08H (0000 1000) for diagnosis**

| Sub-function Code | Description                        |
|-------------------|------------------------------------|
| 0000              | Return to inquire information data |

For example: The inquiry information string is same as the response information string when the loop detection to address 01H of driver is carried out.

The RTU request command is:

|                                |  |
|--------------------------------|--|
| START                          | T1-T2-T3-T4 (transmission time of 3.5 bytes) |
| Node address                   | 01H  |
| Command                        | 08H  |
| High byte of sub-function code | 00H  |
| Low byte of sub-function code  | 00H  |
| High byte of data content      | 12H  |
| Low byte of data content       | ABH  |
| Low byte of CRC                | ADH  |
| High byte of CRC               | 14H  |
| END                            | T1-T2-T3-T4 (transmission time of 3.5 bytes) |

The RTU reply command is:

|                                |  |
|--------------------------------|--|
| START                          | T1-T2-T3-T4 (transmission time of 3.5 bytes) |
| Node address                   | 01H  |
| Command                        | 08H  |
| High byte of sub-function code | 00H  |
| Low byte of sub-function code  | 00H  |
| High byte of data content      | 12H  |
| Low byte of data content       | ABH  |
| Low byte of CRC                | ADH  |
| High byte of CRC               | 14H  |
| END                            | T1-T2-T3-T4 (transmission time of 3.5 bytes) |

The ASCII request command is:

|       |    |
|-------|----|
| START | “: |
|-------|----|

|                                |     |
|--------------------------------|-----|
| Node address                   | '0' |
|                                | '1' |
| Command                        | '0' |
|                                | '8' |
| High byte of sub-function code | '0' |
|                                | '0' |
| Low byte of sub-function code  | '0' |
|                                | '0' |
| High byte of data content      | '1' |
|                                | '2' |
| Low byte of data content       | 'A' |
|                                | 'B' |
| LRC CHK Hi                     | '3' |
| LRC CHK Lo                     | 'A' |
| END Hi                         | CR  |
| END Lo                         | LF  |

The ASCII reply command is:

|                                |     |
|--------------------------------|-----|
| START                          | ·:  |
| Node address                   | '0' |
|                                | '1' |
| Command                        | '0' |
|                                | '8' |
| High byte of sub-function code | '0' |
|                                | '0' |
| Low byte of sub-function code  | '0' |
|                                | '0' |
| High byte of data content      | '1' |
|                                | '2' |
| Low byte of data content       | 'A' |
|                                | 'B' |
| LRC CHK Hi                     | '3' |
| LRC CHK Lo                     | 'A' |
| END Hi                         | CR  |
| END Lo                         | LF  |

## Appendix A: Commissioning guide

### A.1 Runing and parameter-adjusting

After setting application parameters, the parameters should be checked according to function requirement, especially the parameters that are interrelated to peripheral wiring of inverter, such as operation mode, control mode, setting of programmable input/output and selecting of feedback quantity. If there is no mistake, debug system running. Debug running includes motor parameters autotuning, overhaul running, S-curve adjusting of good running, comfortable adjusting of elevator on-off and precision adjusting of elevator flat bed.

#### A.1.1 Motor parameters autotuning

Before beginning to debug elevator, it is recommended that user should carry out tractor parameters autotuning. During autotuning, the motor should be unloaded, the keypad control mode is selected (P0.01=0), and carry out parameter autotuning according to the description of P0.08.

**Note: It is different between the motor parameters autotuning of synchronous motor and asynchronous motor.**

#### A.1.2 Overhaul running

Overhaul running is used to judge whether the elevator is in good running.

During overhaul running, attention should be paid to whether actual running direction of elevator is in accordance with instruction direction, if they are inconsistent, change any two wirings of the output terminal (U,V,W), or adjust P0.06 to be 1.

**Note: Because the parameters should be re-autotuned after changing the motor wiring for synchronous motor, so it is recommended that the user changes elevator running direction by adjusting P0.06.**

#### A.1.3 S-curve adjusting

Before running, verify that whether the control logic and wiring are right. If they are right, carry out the adjusting of S-curve. Refer to the description of P1.08~P1.15.

#### A.1.4 Comfort adjustment during the stopping/starting of the elevator

Set the following parameters to change the comfort of elevator starting: P1.14 (starting speed), P1.15 (holding time of starting speed), P1.08 (starting quadric acceleration), P1.09 (starting acceleration), P3.00 and P3.01 (PI parameter of low speed), P8.06 (contracting brake open delay time). If weighing equipments of analog quantity are used, it is necessary to adjust pre-torque compensation of starting moment. Please refer to each function code to carry out adjusting.

Set the following parameters to change the comfortable of elevator stopping: P1.12



(stopping quadric deceleration), P1.13 (stopping deceleration), P3.00 and P3.01 (PI parameter of low speed), P8.06 (contracting brake close delay time).

**A.1.5 Accuracy adjusting of elevator flat floor**

If leveling error of each floor is different, adjust each position of flashboard to keep the same errors on every floor, and adjust creeping speed of elevator (set by multi-step speed) and P1.12 (stopping quadric deceleration).

**A.2 Elevator running mode**

There are two running modes for CHV180: multi-step speed and analog quantity speed and the Multi-step speed are used as the main mode.

**A.2.1 Multi-step speed mode (Contracting brake and contactor are controlled by inverter)**

In multi-step speed mode, the speed command can be selected by external multi-step terminals. As in the following project of elevator control: contracting brake and contractor are controlled by inverter. Detection the feedback signal of contracting brake and contactor action and overhaul command are controlled by input terminal (EXM). Run speed is given by MS1~ MS3 and the analog quantity of weighing equipment are applied.

Wiring diagram is as follows:

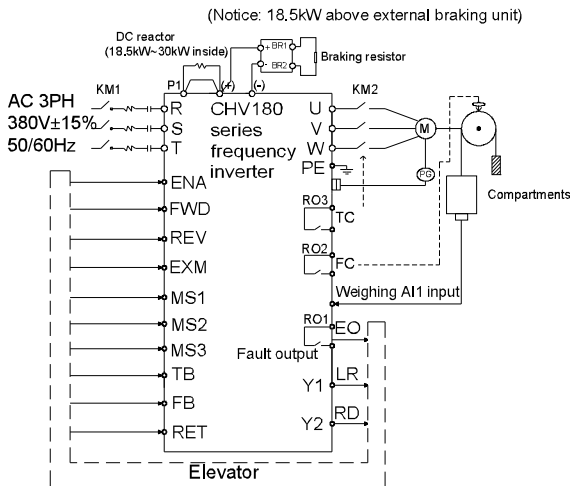

Figure A.1 Wiring principles for Multi-step speed control.

Sequence chart of running is as follows:

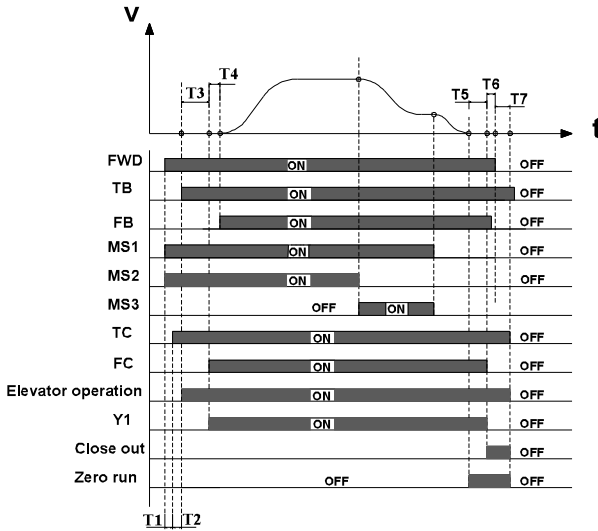

Figure A.2 Sequence chart of running for Multi-step speed control.

The meanings of T1~T7 are as follows:

| Symbol | Meanings   |
|--------|--|
| T1     | The system delay from the time when the inverter receives running signal to the time when the inverter outputs pull-in command of contactor.               |
| T2     | Waiting delay from the time when the inverter outputs contactor pull-in command to the time when the inverter receives contactor feedback signal.          |
| T3     | P8.06 (Contacting brake-closing delay time)  |
| T4     | Waiting delay from the time when the inverter brake-releasing output command to the time when the inverter receives contracting brake feedback signal.     |
| T5     | P8.05 (Contacting brake-releasing delay time)  |
| T6     | Waiting delay from the time when the inverter outputs closing brake command to the time when the inverter receives stopping command from external control. |
| T7     | P8.20 (Inverter stop delay time)   |

The description of sequence chart:

- After inverter receive the running command (FWD) and running speed command

(MS1~MS3), delay the time of T1, the inverter output actuate control command to contactor.

- After T2, when the inverter received the feedback signal of contactor. It is running at 0 speed, and output Y1 at the same time. After T3, the inverter output contracting brake close signal (FC).
- After T4, the inverter received the feedback signal of contracting brake, after affirming it is open completely, the inverter is accelerated running with S-curve.
- After the speed command (MS1~MS3) is cut off, the inverter is decelerated stopping with S-curve. When the speed reaches P8.13 (Stop contracting brake frequency), the inverter output the brake open command (FC) after T5 for cutting off running command.
- After T6, when it receives the stop command, and after T7, the inverter is stop, at the same time the inverter output Releasing command to contactor (TC) and stop signal of elevator. At this time, one operation cycle is over.

**Note:**

Detailed functions of multi-step speed mode are as follows: The logics are the same with controlling contactor and brake signal, controller can control the brake with elevator running 1(LR1) and holding-brake output.

Detailed functions of multi-step speed mode are as follows:

| Function Code | Name                     | Recommendation setting | Remark   |
|---------------|--------------------------|------------------------|--|
| P0.00         | Speed control mode       | 1                      | Vector control with PG   |
| P0.01         | Run command source       | 1                      | Terminal control   |
| P0.02         | Rated speed of elevator  | 1.500m/s               | User setting   |
| P0.03         | Speed command source     | 3                      | Multi-step Speed   |
| P0.04         | Maximum output frequency | 50.00Hz                | User setting   |
| P1.00         | Multi-step Speed 0       | 0                      | Setting parameters according to user's needs, and Multi-step speed 0 is set to be 0m/s |
| P1.01         | Multi-step Speed 1       | Re-flat layer speed    |  |
| P1.02         | Multi-step Speed 2       | Creeping speed         |  |
| P1.03         | Multi-step Speed 3       | Urgency speed          |  |
| P1.04         | Multi-step Speed 4       | Reserved               |  |

| Function Code | Name                              | Recommendation setting   | Remark                   |
|---------------|-----------------------------------|--------------------------|--------------------------|
| P1.05         | Multi-step Speed 5                | Normal low speed         |                          |
| P1.06         | Multi-step Speed 6                | Normal high speed 1      |                          |
| P1.07         | Multi-step Speed 7                | Normal high speed 2      |                          |
| P1.08         | Start quadratic acceleration      | 0.350m/s <sup>3</sup>    | Set by on-site debugging |
| P1.09         | Start acceleration                | 0.700m/s <sup>2</sup>    |                          |
| P1.10         | Speed-down quadratic deceleration | 0.350m/s <sup>3</sup>    |                          |
| P1.11         | Deceleration                      | 0.700m/s <sup>2</sup>    |                          |
| P1.12         | Stop quadratic deceleration       | 0.350m/s <sup>3</sup>    |                          |
| P1.13         | Stop deceleration                 | 0.700m/s <sup>2</sup>    |                          |
| P1.14         | Start speed                       | 0.000m/s                 |                          |
| P1.15         | Start speed holding time          | 0.0s                     |                          |
| P1.16         | Overhaul running speed            | 0.300m/s                 |                          |
| P1.17         | Overhaul running acceleration     | 1.000 m/s <sup>2</sup>   |                          |
| P1.18         | Overhaul running deceleration     | 1.000 m/s <sup>2</sup>   |                          |
| P2.00         | Motor type selection              | Affirm the type of motor | Set by tractor nameplate |
| P2.01         | Tractive roller diameter          | Tractor nameplate        |                          |
| P2.02         | Reduction ratio                   | Tractor nameplate        |                          |
| P2.03         | Hoist rope hanging ratio          | Tractor nameplate        |                          |
| P2.04         | Motor rated power                 | Tractor nameplate        |                          |
| P2.05         | Motor rated frequency             | Tractor nameplate        |                          |

| Function Code | Name                                  | Recommendation setting     | Remark   |
|---------------|---------------------------------------|----------------------------|--|
| P2.06         | Motor rated speed                     | Tractor nameplate          |  |
| P2.07         | Motor rated voltage                   | Tractor nameplate          |  |
| P2.08         | Motor rated current                   | Tractor nameplate          |  |
| P3 group      | Vector control                        | Recommendation setting     | Set by running effect                            |
| P4.00         | Encoder type selection                | Affirm the type of encoder | Set by encoder                                   |
| P4.01         | Number of pulse of encoder            |                            |  |
| P4.02         | Encoder direction                     | 0                          | Set by result of debugging                       |
| P5.02         | S1 terminal function                  | 1                          | Up run (FWD)                                     |
| P5.03         | S2 terminal function                  | 2                          | Down run(REV)                                    |
| P5.04         | S3 terminal function                  | 8                          | Multi-step Speed reference 1(MS1)                |
| P5.05         | S4 terminal function                  | 9                          | Multi-step Speed reference 2(MS2)                |
| P5.06         | S5 terminal function                  | 3                          | Overhaul run(EXM)                                |
| P5.07         | S6 terminal function                  | 19                         | Inverter enable(ENA)                             |
| P5.08         | S7 terminal function                  | 10                         | Multi-step Speed reference 3(MS3)                |
| P5.09         | S8 terminal function                  | 17                         | Contractor feedback (TB)                         |
| P5.10         | S9 terminal function                  | 18                         | Contracting brake feedback(FB)                   |
| P5.11         | S10 terminal function                 | 6                          | Fault reset(RET)                                 |
| P6.04         | Relay 1 output                        | 4                          | Fault output(EO)                                 |
| P6.05         | Relay 2 output                        | 7                          | Contracting brake control(FC)                    |
| P6.06         | Relay 3 output                        | 8                          | Relay control(TC)                                |
| P8.04         | Brake and contactor control selection | 3                          | Inverter control contracting brake and contactor |
| P8.05         | selection of brake                    | 0.0s                       |  |

| Function Code | Name                             | Recommendation setting | Remark                   |
|---------------|----------------------------------|------------------------|--------------------------|
|               | and contactor control mode       |                        | Set by on-site debugging |
| P8.06         | Brake open delay time            | 0.0s                   |                          |
| P8.11         | Brake feedback check time        | 2.0                    |                          |
| P8.12         | Contactor feedback check time    | 2.0                    |                          |
| P8.13         | Stop contracting brake frequency | 0.00Hz                 |                          |
| P8.20         | Stop delay                       | 0.0                    |                          |

**Note: If the inverter is running with multi-step speed, the Multi-step Speed 0 must be set to be 0.**

**A.2.2 Analog quantity speed tracking running mode**

The mode is that speed command is given by analog quantity, and the inverter only runs According to the present value of analog quantity signal, and the running curve of elevator is decided by analog quantity variation curve generated by external controller. The inverter is only responsible for driving the tractor. The input channel of analog quantity tracking running must select AI1.

The wiring diagram of analog quantity speed mode is as follow:

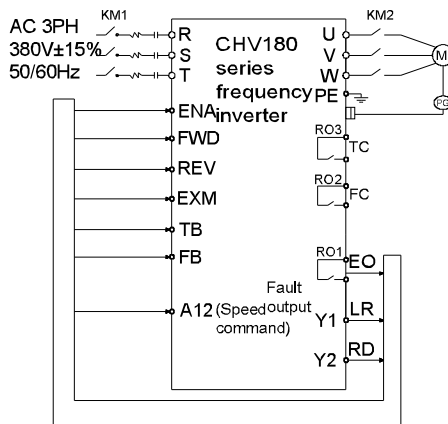

Figure A.3 Wiring diagram of analog quantity mode.

**The time sequence:**

The running time sequence is the same as Multi-step Speed's on the whole. For detailed description, please refer to Figure A.2.

**Note:**

**1) The s-curve of inner inverter is invalid with analog quantity speed tracking running mode. The run s-curve of elevator is generated by external controller. The adjustment of P5.17 or P5.22 will influence the input sensitivity of analog quantity.**

**2) If the change rate of analog quantity is too large it will cause the mutation of running frequency which may result in the over-current or over-voltage occur.**

**A.2.3 Overhaul running**

The wiring diagram of overhaul run mode is as follow:

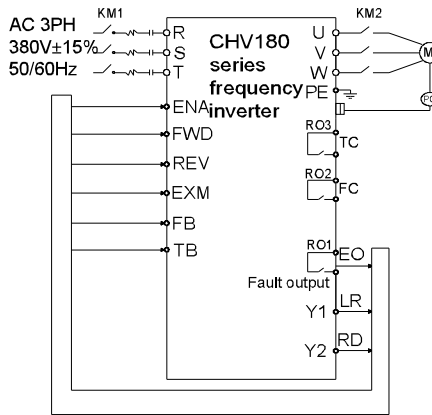

Figure A.4 Wiring diagram of overhaul run mode.

Sequence chart of overhaul running is as follows:

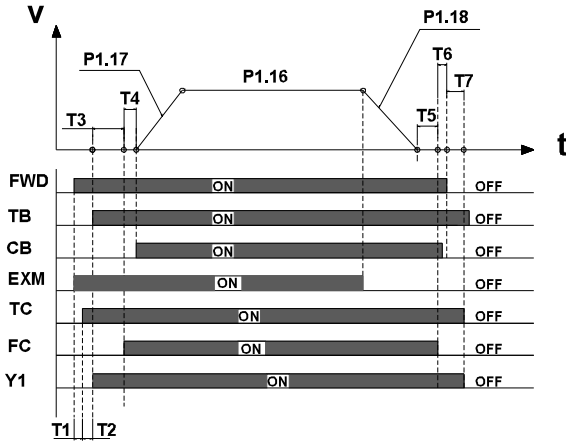

Figure A.5 Sequence chart of overhaul running.

The meanings of T1~T7 are as follows:

| Sign | Meanings   |
|------|--|
| T1   | The time is the system delay time from inverter received running signal to output actuates command of contactor.           |
| T2   | The time is the wait delay time from inverter output contactor actuates command to receive contactor feedback signal.      |
| T3   | P8.06(Contacting brake close delay time)   |
| T4   | The time is the wait delay time form inverter brake-releasing output command to receive contracting brake feedback signal. |
| T5   | P8.05(Contacting brake open delay time)  |
| T6   | The time is the wait delay time from inverter output closed-brake command to receive stopping command of external control. |
| T7   | P8.20(Inverter stop delay time)  |

- After inverter receive the running command (FWD) and emergency running command (EXM), delay the time of T1, the inverter output contactor actuate control command (TC).
- After T2, when the inverter received the feedback signal from contactor, the inverter is running at 0 speed, and output Y1 at the same time. After T3, the inverter output contracting brake closing signal (FC).
- After T4, the inverter received the feedback signal of contracting brake, after affirming it is open completely, the inverter is accelerated running with overhaul run acceleration (P1.17) to reach overhaul running speed(P1.16),and then run at



a constant speed.

- After the overhaul command (EXM) is cut off, the inverter is decelerated stopping with overhaul run deceleration (P1.18). When the speed reaches P8.13, the inverter output the brake open command (FC), after T5 for cutting off running command.
- After T6, when it receives the stop command, and after T7, the inverter is stop, at the same time the inverter output cutting contactor command (TC) and stop signal of elevator (Y1). At this time, one operation cycle is over.

**A.2.4 Emergency running**

The wiring diagram of emergency running is as follows:

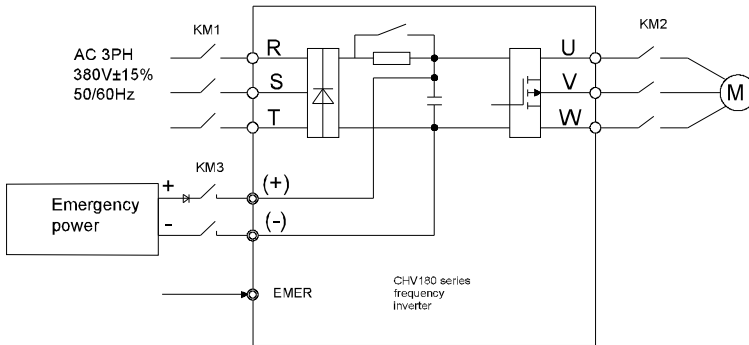

Figure A.6 Wiring diagram of emergency running.

Definition of terminal is as follow:

| Terminal sign | Meanings                             |
|---------------|--------------------------------------|
| EMER          | Emergency run                        |
| FWD           | Up running elevator                  |
| REV           | Down running elevator                |
| (+), (-)      | DC bus voltage terminals of inverter |
| KM            | Control contactor of main power      |
| KM3           | Control contactor of emergency power |

Sequence chart of emergency running is as follows:

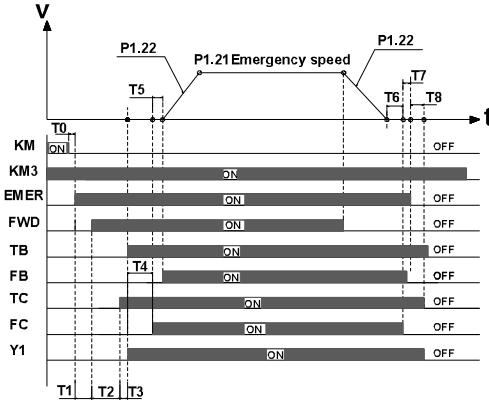

Figure A.7 Sequence chart of emergency run.

The meanings of T0~T8 are as follows:

| Symbol | Description  |
|--------|--|
| T0     | The time is the delay time from the main power is off to the switch of emergency power is on                               |
| T1     | The time is the delay time from the controller output emergency command to output run command                              |
| T2     | The time is the system delay time from inverter received running signal to output actuates command of contactor.           |
| T3     | The time is the wait delay time form inverter output contactor actuates command to receive contactor feedback signal.      |
| T4     | P8.06(Contacting brake close delay time)   |
| T5     | The time is the wait delay time form inverter brake-releasing output command to receive contracting brake feedback signal. |
| T6     | P8.05(Contacting brake open delay time)  |
| T7     | The time is the wait delay time from inverter output closed-brake command to receive stopping command of external control. |
| T8     | P8.20(Inverter stop delay time)  |

- When the main power is off, the controller cut off main power relay (KM1), after T0, the control switch of emergency power will be closed, and output emergency command at the same time , after T1, the inverter receive running command from controller, then after T2, the inverter output actuate command to contactor.
- After T3, the inverter received the feedback signal from contactor, then the .121.

inverter start to run at zero speed, at the same time output running signal (Y1).

After T4, the inverter output brake closed signal (FC).

- After T5, the inverter received brake feedback signal(FB), after affirming the brake is open completely ,the inverter accelerate with emergency acceleration (P1.22) reach to emergency speed (P1.21), and then run at a constant speed.
- When elevator run to flat floor, the controller will cut off emergency command (EMER), and the inverter begin to decelerate to stop with emergency deceleration (P1.22), when decelerate to P8.13, after T6, the inverter output brake open command (FC), and the controller cut off running command.
- After T7, the inverter receives stop command, and then after the delay time of T8, the inverter stop, and output releasing command (TC) to contactor and stop signal (Y1) of elevator. At this time, one operation cycle is over.

## Appendix B: Dimension of the inverter

### B.1 External dimension

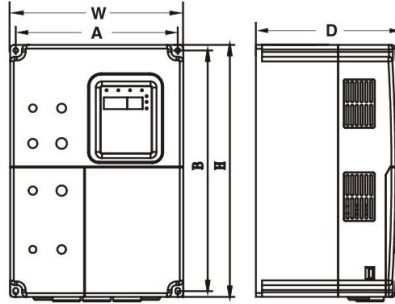

Figure B.1 Dimensions (15kW and below).

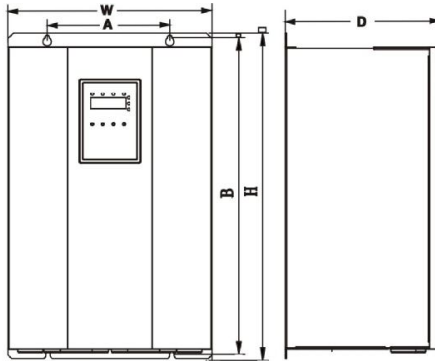
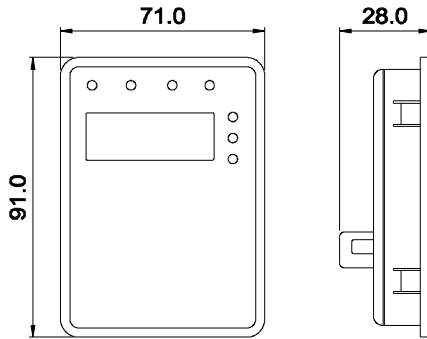

Figure B.2 Dimensions (18.5~30kW).

| Power (kW) | Size | A (mm)                 | B (mm) | H (mm)             | W (mm) | D (mm) | Installation Hole (mm) |
|------------|------|------------------------|--------|--------------------|--------|--------|------------------------|
|            |      | Installation Dimension |        | External Dimension |        |        |                        |
| 4.0~5.5    | C    | 147.5                  | 237.5  | 250                | 160    | 175    | 5                      |
| 7.5~15     | D    | 206                    | 305.5  | 320                | 220    | 180    | 6                      |
| 18.5~30    | E    | 176                    | 454.5  | 467                | 290    | 215    | 6.5                    |

## B.2 Dimensions of external keypad



FigureB.3 Dimension of small keypad.

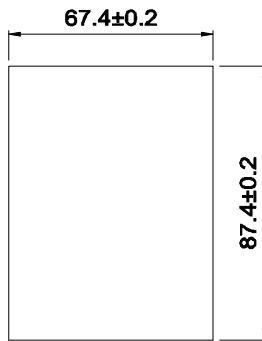

Figure B.4 Dimension of big keypad.

### B.3 Installation space

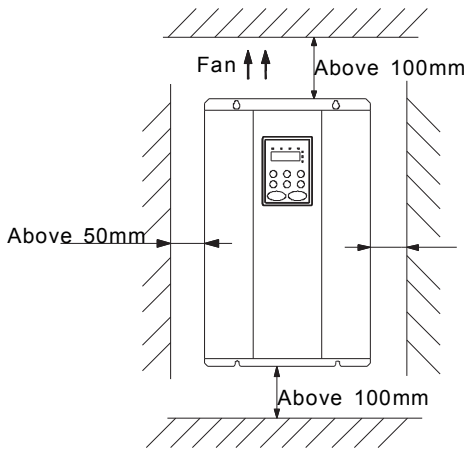

Figure B.5 Safety space.

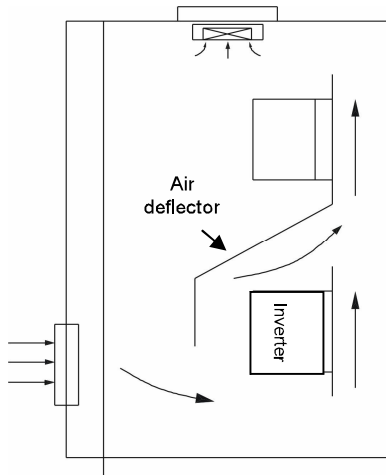

Figure B.6 Installation of multiple inverters.

**Note: Add the air deflector when apply the up-down installation.**

## B.4 Disassembly and installation

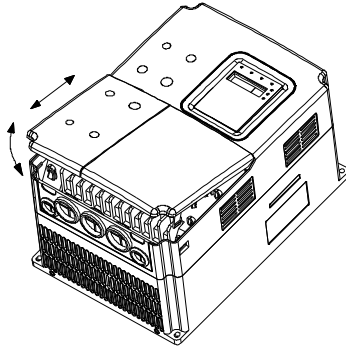
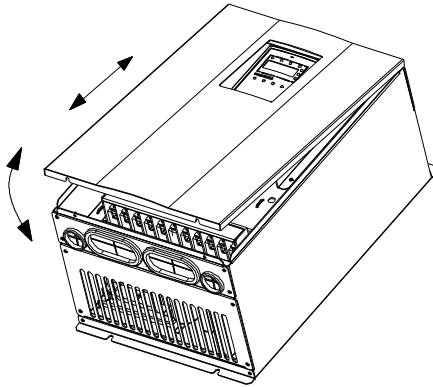

Figure B.7 Disassembly of plastic cover.



FigureB.8 Disassembly of metal plate cover.

## Appendix C: Specification of accessories

### C.1 Specifications of breaker, cable, contactor and reactor

#### C.1.1 Specifications of breaker, cable and contactor

| Model No.     | Circuit breaker (A) | Input/output cable (mm <sup>2</sup> ) (Copper wire) | Rated current of contactor (A) (380V) |
|---------------|---------------------|---|---------------------------------------|
| CHV180-004G-4 | 25                  | 4   | 16                                    |
| CHV180-5R5G-4 | 25                  | 4   | 16                                    |
| CHV180-7R5G-4 | 40                  | 6   | 25                                    |
| CHV180-011G-4 | 63                  | 6   | 32                                    |
| CHV180-015G-4 | 63                  | 6   | 50                                    |
| CHV180-018G-4 | 100                 | 10  | 63                                    |
| CHV180-022G-4 | 100                 | 16  | 80                                    |
| CHV180-030G-4 | 125                 | 25  | 95                                    |

#### C.1.2 Specifications of AC input/output and DC reactor

| Model No.     | AC Input reactor |            | AC Output reactor |            | DC reactor |            |
|---------------|------------------|------------|-------------------|------------|------------|------------|
|               | Current          | Inductance | Current           | Inductance | Current    | Inductance |
|               | (A)              | (mH)       | (A)               | (mH)       | (A)        | (mH)       |
| CHV180-004G-4 | 10               | 1.5        | 10                | 0.6        | 12         | 6.3        |
| CHV180-5R5G-4 | 15               | 1.0        | 15                | 0.25       | 23         | 3.6        |
| CHV180-7R5G-4 | 20               | 0.75       | 20                | 0.13       | 23         | 3.6        |
| CHV180-011G-4 | 30               | 0.60       | 30                | 0.087      | 33         | 2          |
| CHV180-015G-4 | 40               | 0.42       | 40                | 0.066      | 33         | 2          |
| CHV180-018G-4 | 50               | 0.35       | 50                | 0.052      | 40         | 1.3        |
| CHV180-022G-4 | 60               | 0.28       | 60                | 0.045      | 50         | 1.08       |
| CHV180-030G-4 | 80               | 0.19       | 80                | 0.032      | 65         | 0.80       |

Note: The machine of E, F and G are embedded with DC reactors.

#### C.1.3 Specification of input filter and output filter

| Inverter capacity (kW) | Input filter model | Output filter model |
|------------------------|--------------------|---------------------|
| CHV180-004G-4          | NFI-010            | NFO-010             |
| CHV180-5R5G-4          | NFI-020            | NFO-020             |
| CHV180-7R5G-4          | NFI-020            | NFO-020             |



| Inverter capacity (kW) | Input filter model | Output filter model |
|------------------------|--------------------|---------------------|
| CHV180-011G-4          | NFI-036            | NFO-036             |
| CHV180-015G-4          | NFI-036            | NFO-036             |
| CHV180-018G-4          | NFI-050            | NFO-050             |
| CHV180-022G-4          | NFI-050            | NFO-050             |
| CHV180-030G-4          | NFI-065            | NFO-065             |

## C.2 Braking resistor/unit selection

### C.2.1 Selection reference

When all the control devices driven by the inverter need quick braking, the braking units need to consume the energy which is feedbacked to the DC bus. In CHV series inverters, the inverters below 15kW (including 15kW) are embedded with braking units and the inverters above 18.5kW (including 18.5kW) should select external braking units. It is necessary to select proper braking resistor according to the inverter capacity. In the application with 100% braking torque and 20% utilization rate of the braking unit, the braking resistor and braking unit are shown as below. For the load which works in the braking state for a long time, it is necessary to adjust the braking power according to the braking torque and utilization rate of the braking. Counting at a long working time, the power of the braking resistor is:  $p = (P_{8.07})^2 / R$ , R is the braking resistor

| Capacity (kW) | Braking unit |          | Braking resistor (100% braking torque and 20% usage rate) |               |          |
|---------------|--------------|----------|---|---------------|----------|
|               | Order No.    | Quantity | Resistor  | Braking power | Quantity |
| 4             | Built-in     | 1        | 122Ω  | 1200W         | 1        |
| 5.5           |              | 1        | 65Ω   | 1600W         | 1        |
| 7.5           |              | 1        | 50Ω   | 1600W         | 1        |
| 11            |              | 1        | 40Ω   | 4800W         | 1        |
| 15            |              | 1        | 32Ω   | 4800W         | 1        |
| 18.5          | DBU-055-4    | 1        | 28Ω   | 6000W         | 1        |
| 22            |              | 1        | 20Ω   | 9600W         | 1        |
| 30            |              | 1        | 16Ω   | 9600W         | 1        |

#### Note:

Select the resistor and power of the braking unit according to the data our company provided.

The braking resistor may increase the braking torque of the inverter. The

resistor power in the above table is designed on 100% braking torque and 20% braking usage ratio. If the users need more braking torque, the braking resistor can decrease properly and the power needs to be magnified.

In the cases where it needs frequent braking (the utilization rate exceeds 20%), it is necessary to increase the power of the braking resistor according to the situation.

When using the external braking units, please see the instructions of the energy braking units to set the voltage degree of the braking unit. Incorrect voltage degree may affect the normal running of the inverter.

**C.2.2 Connection**

**C.2.2.1 Connection of braking resistor**

For the inverter below 15kW (including 15kW), please refer to the figure below.

**C.2.2.2 Connection of braking unit**

For the inverter above 18.5kW (including 18.5kW), please refer to the figure below.

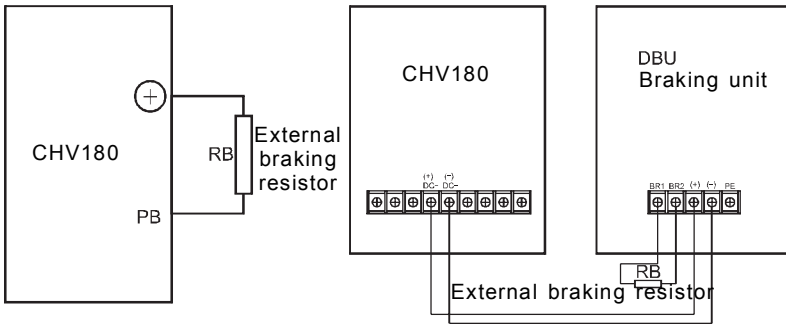

Figure C-1 Installation of braking resistor

Figure C-2 Installation of braking unit

## Appendix D Function parameters

The function parameters of CHV100 series inverters have been divided into 16 groups (P0~PE) according to the function. Each function group contains certain function codes applying 3-class menus. For example, "P8.08" means the eighth function code in the P8 group function, PE group is factory reserved, and users are forbidden to access these parameters.

For the convenience of function codes setting, the function group number corresponds to the first class menu, the function code corresponds to the second class menu and the function code corresponds to the third class menu.

1. Below is the instruction of the function lists:

**The first line** "Function code": codes of function parameter group and parameters;

**The second line** "Name": full name of function parameters;

**The third line** "Description": detailed illustration of the function parameters

**The forth line** "Factory Setting": the original factory set value of the function parameter;

**The fifth line** "Modify ": the modifying character of function codes (the parameters can be modified or not and the modifying conditions), below is the instruction:

"○": means the set value of the parameter can be modified on stop and running state;

"◎": means the set value of the parameter can not be modified on the running state;

"●": means the value of the parameter is the real detection value which can not be modified.

**The sixth line** "LCD Display": simple illustration for the function parameters

(The inverter has limited the automatic inspection of the modifying character of the parameters to help users avoid mismodifying)

2. "LCD Display" is only valid when external LCD operational panel is used.

3." Factory setting" means the function parameter will restore to the default value during default parameters restoring. But the detected parameter or recorded value won't be restored.

4. For a better parameter protection, the inverter provides password protection to the

parameters. After setting the password (set P7.00 to any non-zero number), the system will come into the state of password verification firstly after the user press **PRG/ESC** to come into the function code editing state. And then“-----” will be displayed. Unless the user input right password, they cannot enter into the system. For the factory setting parameter zone, it needs correct factory password (remind that the users can not modify the factory parameters by themselves, otherwise, if the parameter setting is incorrect, damage to the inverter may occur). If the password protection is unlocked, the user can modify the password freely and the inverter will work as the last setting one. When P7.00 is set to 0, the password can be canceled. If P7.00 is not 0 during powering on, then the parameter is protected by the password. WWhen modify the parameters by serial communication, the function of the password follows the above rules, too.

| Function Code                   | Name                 | Description   | Factory Setting | Modify | LCD Display  |
|---------------------------------|----------------------|---|-----------------|--------|--------------|
| <b>P0 Group: Basic function</b> |                      |   |                 |        |              |
| P0.00                           | Speed control mode   | 0:Sensorless vector control<br>1:Vector control With PG<br>2:V/F control                            | 1               | ☉      | CONTROL MODE |
| P0.01                           | Run command source   | 0: Keypad<br>1: Terminal<br>2: Communication  | 1               | ☉      | RUN COMMAND  |
| P0.02                           | Elevator rated speed | 0.100~4.00m/s   | 1.500m/s        | ☉      | RATED SPEED  |
| P0.03                           | Speed command source | 0: Keypad<br>1: AI1<br>2: AI2<br>3: Multi-Step speed<br>4: Communication<br>5: AI1 tracking running | 3               | ☉      | SPEED SOURCE |
| P0.04                           | Maximum frequency    | 10.0~400.00Hz   | 50.00Hz         | ☉      | MAX FREQ     |
| P0.05                           | Keypad reference     | 0.00 Hz ~ P0.02   | 1.500m/s        | ○      | KEYPAD REF   |

| Function Code                | Name                        | Description   | Factory Setting | Modify | LCD Display        |
|------------------------------|-----------------------------|---|-----------------|--------|--------------------|
|                              | speed                       |   |                 |        | SPEED              |
| P0.06                        | Running direction selection | 0: Forward<br>1: Reverse<br>2: Forbid reverse   | 0               | ☉      | RUN DIRECTION      |
| P0.07                        | Carrier frequency           | 1.0~16.0kHz   | Depend on model | ○      | CARRIER FREQ       |
| P0.08                        | Motor parameters autotuning | 0: No action<br>1: Rotation autotuning<br>2: Static autotuning  | 0               | ☉      | AUTOTUNING         |
| P0.09                        | Restore parameters          | 0: No action<br>1: Restore factory setting<br>2: Clear fault records<br>3: Restore parameters for injection molding machine | 0               | ☉      | RESTORE PARA       |
| P0.10~P0.11                  | Reserved                    | 0~65536   | 0               | ☉      | RESERVE            |
| <b>P1 Group: Speed curve</b> |                             |   |                 |        |                    |
| P1.00                        | Multi-step speed 0          | 0.000~P0.02   | 0.000m/s        | ○      | MULTI-STEP SPEED 0 |
| P1.01                        | Multi-step speed 1          | 0.000~P0.02   | 0.000m/s        | ☉      | MULTI-STEP SPEED 1 |
| P1.02                        | Multi-step speed 2          | 0.000~P0.02   | 0.000m/s        | ☉      | MULTI-STEP SPEED 2 |
| P1.03                        | Multi-step speed 3          | 0.000~P0.02   | 0.000m/s        | ☉      | MULTI-STEP SPEED 3 |
| P1.04                        | Multi-step speed 4          | 0.000~P0.02   | 0.000m/s        | ☉      | MULTI-STEP SPEED 4 |
| P1.05                        | Multi-step speed 5          | 0.000~P0.02   | 0.000m/s        | ☉      | MULTI-STEP SPEED 5 |
| P1.06                        | Multi-step speed 6          | 0.000~P0.02   | 0.000m/s        | ☉      | MULTI-STEP         |

| Function Code | Name                            | Description                   | Factory Setting        | Modify | LCD Display              |
|---------------|---------------------------------|-------------------------------|------------------------|--------|--------------------------|
|               |                                 |                               |                        |        | SPEED 6                  |
| P1.07         | Multi-step speed 7              | 0.000~P0.02                   | 0.000m/s               | ☉      | MULTI-STEP SPEED 7       |
| P1.08         | Start quadric acceleration      | 0.001~10.000 m/s <sup>3</sup> | 0.350m/s <sup>3</sup>  | ☉      | START QUADRIC ACCEL      |
| P1.09         | Start acceleration              | 0.001~10.000 m/s <sup>2</sup> | 0.700m/s <sup>2</sup>  | ☉      | START ACCEL              |
| P1.10         | Speed-down quadric deceleration | 0.001~10.000 m/s <sup>3</sup> | 0.350m/s <sup>3</sup>  | ☉      | SPEED-DOWN QUADRIC DECEL |
| P1.11         | Deceleration                    | 0.001~10.000 m/s <sup>2</sup> | 0.700m/s <sup>2</sup>  | ☉      | DECEL                    |
| P1.12         | Stop quadric deceleration       | 0.001~10.000 m/s <sup>3</sup> | 0.350m/s <sup>3</sup>  | ☉      | STOP QUADRIC DECEL       |
| P1.13         | Stop deceleration               | 0.001~10.000 m/s <sup>2</sup> | 0.700m/s <sup>2</sup>  | ☉      | STOP DECEL               |
| P1.14         | Start speed                     | 0.000~0.250 m/s               | 0.000m/s               | ☉      | START SPEED              |
| P1.15         | Start holding time              | 0.0~5.0s                      | 0.0s                   | ☉      | START HOLDING            |
| P1.16         | Overhaul running speed          | 0.000 m/s~P0.02               | 0.300m/s               | ☉      | OVERHAUL RUNNING TIME    |
| P1.17         | Overhaul running acceleration   | 0.001~10.000 m/s <sup>2</sup> | 1.000m/s <sup>2</sup>  | ☉      | OVERHAUL RUNNING ACCEL   |
| P1.18         | Overhaul running deceleration   | 0.001~10.000 m/s <sup>2</sup> | 1.000m/s <sup>2</sup>  | ☉      | OVERHAUL RUNNING DECEL   |
| P1.19         | Motor autotuning acceleration   | 0.001~10.000 m/s <sup>2</sup> | 0.600 m/s <sup>2</sup> | ☉      | MOTOR AUTOTUNING ACCEL   |

| Function Code | Name  | Description                                 | Factory Setting       | Modify | LCD Display                       |
|---------------|---|---|-----------------------|--------|-----------------------------------|
| P1.20         | Motor autotuning deceleration               | 0.001~10.000 m/s <sup>2</sup>               | 0.600m/s <sup>2</sup> | ☉      | MOTOR AUTOTUNING DECEL            |
| P1.21         | Emergence running speed                     | 0.000~P0.02 m/s                             | 0.300m/s              | ☉      | EMERGENCE RUNNING ACCEL           |
| P1.22         | Emergence running acceleration/deceleration | 0.001~10.000 m/s <sup>2</sup>               | 1.000m/s <sup>2</sup> | ☉      | EMERGENCE RUNNING DECEL           |
| P1.23         | Forced deceleration speed 1                 | P1.25~10.000 m/s <sup>2</sup>               | 1.000m/s <sup>2</sup> | ☉      | FORCED DECELERATION DECEL 1       |
| P1.24         | Forced deceleration speed 1 detection       | 0.0~P1.26                                   | 20.0%                 | ☉      | FORCED DECELERATION SPEED 1 CHECK |
| P1.25         | Forced deceleration speed 2                 | P1.27~P1.23 m/s <sup>2</sup>                | 0.900m/s <sup>2</sup> | ☉      | FORCED DECELERATION DECEL 2       |
| P1.26         | Forced deceleration speed 2 detection       | P1.24~P1.28                                 | 40.0%                 | ☉      | FORCED DECELERATION SPEED 2 CHECK |
| P1.27         | Forced deceleration speed 3                 | 0.001~P1.25 m/s <sup>2</sup>                | 0.700m/s <sup>2</sup> | ☉      | FORCED DECELERATION DECEL 3       |
| P1.28         | Forced deceleration speed 3 detection       | P1.26~100.0%                                | 80.0%                 | ☉      | FORCED DECELERATION SPEED 3 CHECK |
| P1.29         | Stop mode selection                         | 0: Deceleration to stop<br>1: Coast to stop | 1                     | ☉      | STOP MODE                         |

| Function Code                     | Name                             | Description                                   | Factory Setting | Modify | LCD Display              |
|-----------------------------------|----------------------------------|---|-----------------|--------|--------------------------|
| P1.30~P1.31                       | Reserved                         | 0~65535                                       | 0               | ☉      | RESERVE                  |
| <b>P2 Group: Motor parameters</b> |                                  |   |                 |        |                          |
| P2.00                             | Motor model                      | 0: asynchronous motor<br>1: synchronous motor | 0               | ☉      | INVERTER MODEL           |
| P2.01                             | Wheel diameter of traction motor | 100~2000mm                                    | 500mm           | ☉      | TRACTION MOTOR WHEEL DIA |
| P2.02                             | Reduction ratio                  | 1.00~100.00                                   | 30.00           | ☉      | SPEED-DOWN RATE          |
| P2.03                             | Hoist rope hanging ratio         | 1~8   | 1               | ☉      | TOW HANGING RATE         |
| P2.04                             | Motor rated power                | 0.4~900.0kW                                   | Depend on model | ☉      | MOTOR RATE POWER         |
| P2.05                             | Motor rated frequency            | 0.01Hz~P0.04                                  | 50.00Hz         | ☉      | MOTOR RATE FREQ          |
| P2.06                             | Motor rated speed                | 1~36000rpm                                    | 1460 rpm        | ☉      | MOTOR RATE SPEED         |
| P2.07                             | Motor rated voltage              | 1~460V  | 380V            | ☉      | MOTOR RATE VOLT          |
| P2.08                             | Motor rated current              | 0.1~1000.0A                                   | Depend on model | ☉      | MOTOR RATE CURR          |
| P2.09                             | Motor rated power factor         | 0.05~1.00                                     | 0.86            | ☉      | MOTOR RATE POWER FACTOR  |
| P2.10                             | Motor stator resistor            | 0.001~65.535Ω                                 | Depend on model | ○      | STATOR RESISTOR          |
| P2.11                             | Motor rotor resistor             | 0.001~65.535Ω                                 | Depend on       | ○      | ROTOR                    |



| Function Code                   | Name                                      | Description  | Factory Setting | Modify                           | LCD Display             |
|---------------------------------|---|--------------|-----------------|----------------------------------|-------------------------|
|                                 |   |              | model           |                                  | RESISTOR                |
| P2.12                           | Stator and rotor inductance               | 0.1~6553.5mH | Depend on model | <input type="radio"/>            | LEAK INDUCTOR           |
| P2.13                           | Motor mutual inductance                   | 0.1~6553.5mH | Depend on model | <input type="radio"/>            | MUTUAL INDUCTOR         |
| P2.14                           | Motor current without load                | 0.01~655.35A | Depend on model | <input type="radio"/>            | NO LOAD CURR            |
| P2.15~P2.16                     | Reserved                                  | 0~65535      | 0               | <input checked="" type="radio"/> | RESERVE FUNCTION        |
| <b>P3 Group: Vector control</b> |   |              |                 |                                  |                         |
| P3.00                           | ASR low speed proportional gain           | 0~100        | 20              | <input type="radio"/>            | ASR Kp1                 |
| P3.01                           | ASR low speed integral time               | 0.01~10.00s  | 0.50s           | <input type="radio"/>            | ASR Ki1                 |
| P3.02                           | Speed detection low speed filtrate times  | 0 ~ 9        | 3               | <input type="radio"/>            | SPEED INSPECT FILTER T1 |
| P3.03                           | Switch low point frequency                | 0.00Hz~P3.07 | 5.00Hz          | <input type="radio"/>            | ASR SWITCHPOINT T1      |
| P3.04                           | ASR high speed proportional gain          | 0~100        | 25              | <input type="radio"/>            | ASR Kp2                 |
| P3.05                           | ASR high speed integral time              | 0.01~10.00s  | 1.00s           | <input type="radio"/>            | ASR Ki2                 |
| P3.06                           | Speed detection high speed filtrate times | 0~9          | 3               | <input type="radio"/>            | SPEED INSPECT FILTER T1 |
| P3.07                           | Switch high point frequency               | P3.03~P0.04  | 10.00Hz         | <input type="radio"/>            | ASR SWITCHPOINT T2      |
| P3.08                           | ACR proportional gain P                   | 0~65535      | 500             | <input type="radio"/>            | ACR P                   |

| Function Code                      | Name  | Description  | Factory Setting | Modify                           | LCD Display               |
|------------------------------------|---|--|-----------------|----------------------------------|---------------------------|
| P3.09                              | ACR integral gain I                               | 0~65535  | 500             | <input type="radio"/>            | ACR I                     |
| P3.10                              | Slip compensation rate of drive side              | 50.0~200.0%  | 100%            | <input type="radio"/>            | DRIVE SLIP COMP           |
| P3.11                              | Slip compensation rate of trig side               | 50.0~200.0%  | 100%            | <input type="radio"/>            | TRIG SLIP COMP            |
| P3.12                              | Torque upper limit                                | 0.0~200.0%(rated current of inverter)                        | 150.0%          | <input type="radio"/>            | TORQUE LIMIT              |
| P3.13~<br>P3.14                    | Reserve function                                  | 0~65535  | 0               | <input checked="" type="radio"/> | RESERVE FUNCTION          |
| <b>P4 Group: Encoder parameter</b> |   |  |                 |                                  |                           |
| P4.00                              | Encoder type selection                            | 0: Increment encoder<br>1: SIN/COS encoder<br>2: UVM encoder | 1               | <input checked="" type="radio"/> | ENCODE TYPR               |
| P4.01                              | PG pulse number                                   | 1~65536  | 1000            | <input checked="" type="radio"/> | TORQUE BOOST              |
| P4.02                              | PG direction selection                            | 0: forward<br>1: reverse                                     | 0               | <input checked="" type="radio"/> | BOOST CUT-OFF             |
| P4.03                              | Magnetic pole initial position                    | 0.00~360.00  | 0.00            | <input checked="" type="radio"/> | POLE INITIAL POSITION     |
| P4.04                              | Thread break detection time of encoder low speed  | 0.0~100.0s<br>(0.0 means don't detect)                       | 1.0             | <input checked="" type="radio"/> | THREAD BREAK DETECTION T1 |
| P4.05                              | Thread break detection time of encoder high speed | 0.0~100.0s<br>(0.0 means don't detect)                       | 1.0             | <input checked="" type="radio"/> | THREAD BREAK DETECTION T2 |
| P4.06                              | Reverse detection time of encoder                 | 0.0~100.0s<br>(0.0 means don't detect)                       | 1.0             | <input checked="" type="radio"/> | REVERSE DETECTION TIME    |
| P4.07                              | Magnetic pole position amplitude gain             | 0.50~1.50  | 1.00            | <input checked="" type="radio"/> | POLE POSITION             |

| Function Code                    | Name  | Description                               | Factory Setting | Modify | LCD Display            |
|----------------------------------|---|---|-----------------|--------|------------------------|
|                                  |   |   |                 |        | AMP PLUS               |
| P4.08                            | C phase pole position offset                    | 0~1024                                    | 512             | ☉      | C POLE POSITION OFFSET |
| P4.09                            | D phase pole position offset                    | 0~1024                                    | 512             | ☉      | D POLE POSITION OFFSET |
| P4.10                            | Synchronous motor static identification current | 10.0%~150.0%                              | 50.0%           |        |                        |
| P4.11~P4.13                      | Reserved  | 0~65535                                   | 0               | ☉      |                        |
| <b>P5 Group: Input terminals</b> |   |   |                 |        |                        |
| P5.00                            | Terminal input mode selection                   | 0~0x3FF                                   | 0               | ☉      | INPUT MODE             |
| P5.01                            | Terminal function input selection               | 0: Invalid<br>1: Valid                    | 0               | ☉      | INPUT SELECTION        |
| P5.02                            | S1 Terminal function                            | 0:Invalid<br>1: Up running                | 1               | ☉      | S1 FUNCTION            |
| P5.03                            | S2 Terminal function                            | 2: Down running<br>3: Examine running     | 2               | ☉      | S2 FUNCTION            |
| P5.04                            | S3 Terminal function                            | 4: Emergency running<br>5: Free stop      | 8               | ☉      | S3 FUNCTION            |
| P5.05                            | S4 Terminal function                            | 6: Fault reset<br>7: Exterior fault input | 9               | ☉      | S4 FUNCTION            |
| P5.06                            | S5 Terminal function                            | 8~10: Multi-speed terminals 1~3           | 3               | ☉      | S5 FUNCTION            |
| P5.07                            | S6 Terminal function                            | 11~13: Uplink forcing deceleration 1~3    | 0               | ☉      | S6 FUNCTION            |
| P5.08                            | S7 Terminal function                            | 14~16: Downlink forcing deceleration      | 0               | ☉      | S7 FUNCTION            |
| P5.09                            | S8 Terminal function                            | 1~3                                       | 0               | ☉      | S8                     |

| Function Code                     | Name                                  | Description  | Factory Setting | Modify | LCD Display        |
|-----------------------------------|---------------------------------------|--|-----------------|--------|--------------------|
|                                   |                                       | 17: Contactor  |                 |        | FUNCTION           |
| P5.10                             | S9 Terminal function                  | feedback signal<br>18: Brake feedback  | 0               | ☉      | S9<br>FUNCTION     |
| P5.11                             | S10 Terminal function                 | signal<br>19: Inverter enable<br>20: Forcing<br>deceleration stop<br>21~40: reversed | 0               | ☉      | S10<br>FUNCTION    |
| P5.12                             | Switch signal filter times            | 1~10   | 5               | ○      | Sx FILTER<br>TIMES |
| P5.13                             | AI1 lower limit                       | 0.00V~P5.15  | 0.00V           | ○      | AI1 LOW<br>LIMIT   |
| P5.14                             | AI1 lower limit corresponding setting | -100.0%~100.0%   | 0.0%            | ○      | AI1 LOW<br>SETTING |
| P5.15                             | AI1 upper limit                       | P5.13~10.00V   | 10.00V          | ○      | AI1 UP LIMIT       |
| P5.16                             | AI1 upper limit corresponding setting | -100.0%~100.0%   | 100.0%          | ○      | AI1 UP<br>SETTING  |
| P5.17                             | AI1 filter time constant              | 0.00s~10.00s   | 0.10s           | ○      | AI1 FILTER<br>TIME |
| P5.18                             | AI2 lower limit                       | 0.00V~P5.20  | 0.00V           | ○      | AI2 LOW<br>LIMIT   |
| P5.19                             | AI2 lower limit corresponding setting | -100.0%~100.0%   | 0.0%            | ○      | AI2 LOW<br>SETTING |
| P5.20                             | AI2 upper limit                       | P5.18~10.00V   | 5.00V           | ○      | AI2 UP LIMIT       |
| P5.21                             | AI2 upper limit corresponding setting | -100.0%~100.0%   | 100.0%          | ○      | AI2 UP<br>SETTING  |
| P5.22                             | AI2 filter time constant              | 0.00s~10.00s   | 0.10s           | ○      | AI2 FILTER<br>TIME |
| <b>P6 Group: Output terminals</b> |                                       |  |                 |        |                    |
| P6.00                             | HDO output selection                  | 0: High-speed pulse output<br>1: ON-OFF output                                       | 0               | ☉      | HDO<br>SELECTION   |

| Function Code | Name   | Description   | Factory Setting | Modify                | LCD Display       |
|---------------|--|---|-----------------|-----------------------|-------------------|
| P6.01         | Y1 output selection                                  | 0: NO output<br>1: Elevator running   | 1               | <input type="radio"/> | Y1<br>SELECTION   |
| P6.02         | Y2 output selection                                  | 2: Up running<br>3: Down running  | 0               | <input type="radio"/> | Y2<br>SELECTION   |
| P6.03         | HDO open collector output selection                  | 4: Fault output<br>5: Zero speed running  | 0               | <input type="radio"/> | HDO<br>SELECTION  |
| P6.04         | Relay 1 output selection                             | 6: Ready<br>7: Brake control  | 4               | <input type="radio"/> | RO1<br>SELECTION  |
| P6.05         | Relay 2 output selection                             | 8: Contactor control<br>9: Frequency reached  | 5               | <input type="radio"/> | RO2<br>SELECTION  |
| P6.06         | Relay 3 output selection                             | 10: FDT reached<br>11: Elevator running<br>12: Holding-brake output<br>13~20: Reserved                | 0               | <input type="radio"/> | RO3<br>SELECTION  |
| P6.07         | AO1 function selection                               | 1:Running speed<br>2:Reference speed  | 0               | <input type="radio"/> | AO1<br>SELECTION  |
| P6.08         | AO2 function selection                               | 3:Motor running speed<br>4:Output current   | 1               | <input type="radio"/> | AO2<br>SELECTION  |
| P6.09         | HDO open collector high speed pulse output selection | 5:Output voltage<br>6:Output power<br>7:Output torque<br>8:A11 input<br>9:A12 input<br>10~14:Reserved | 0               | <input type="radio"/> | HDO<br>SELECTION  |
| P6.10         | AO1 lower limit                                      | 0.0%~P6.12  | 0.0%            | <input type="radio"/> | AO1 LOW<br>LIMIT  |
| P6.11         | AO1 lower limit corresponding output                 | 0.00V ~10.00V   | 0.00V           | <input type="radio"/> | AO1 LOW<br>OUTPUT |
| P6.12         | AO1 upper limit                                      | P6.10~100.0%  | 100.0%          | <input type="radio"/> | AO1 UP<br>LIMIT   |
| P6.13         | AO1 upper limit corresponding output                 | 0.00V ~10.00V   | 10.00V          | <input type="radio"/> | AO1 UP<br>OUTPUT  |
| P6.14         | AO2 lower limit                                      | 0.0%~P6.16  | 0.0%            | <input type="radio"/> | AO2 LOW           |

| Function Code                      | Name                                 | Description  | Factory Setting | Modify | LCD Display        |
|------------------------------------|--------------------------------------|--|-----------------|--------|--------------------|
|                                    |                                      |  |                 |        | LIMIT              |
| P6.15                              | AO2 lower limit corresponding output | 0.00V ~10.00V  | 0.00V           | ○      | AO2 LOW OUTPUT     |
| P6.16                              | AO2 upper limit                      | P6.14~100.0%   | 100.0%          | ○      | AO1 UP LIMIT       |
| P6.17                              | AO2 upper limit corresponding output | 0.00V ~10.00V  | 10.00V          | ○      | AO2 UP OUTPUT      |
| P6.18                              | AO3 lower limit                      | 0.0%~P6.20   | 0.0%            | ○      | HDO LOW LIMIT      |
| P6.19                              | HDO lower limit corresponding output | 0.0 ~ 50.0kHz  | 0.0kHz          | ○      | HDO LOW OUTPUT     |
| P6.20                              | AO3 upper limit                      | P6.18~100.0%   | 100.0%          | ○      | HDO UP LIMIT       |
| P6.21                              | HDO upper limit corresponding output | 0.0 ~ 50.0kHz  | 50.0kHz         | ○      | HDO UP OUTPUT      |
| P6.22                              | FDT level detection value            | 0.00~P0.07   | 50.00Hz         | ○      | FDT LEVEL          |
| P6.23                              | FDT lag detection value              | 0.0~100.0  | 5.0%            | ○      | FDT LAG            |
| P6.24                              | Frequency arrival detecting range    | 0.00~100.0%  | 0.0%            | ○      | FREQ ARRIVE DETECT |
| P6.25~P6.26                        | Reserved                             | 0~65535  | 0               | ◎      | RESERVE            |
| <b>P7 Group: Display interface</b> |                                      |  |                 |        |                    |
| P7.00                              | User password                        | 0~65535  | 0               | ○      | USER PASSWORD      |
| P7.01                              | LCD language selection               | 0: Chinese<br>1: English                                 | 0               | ○      | LANGUAGE SELECT    |
| P7.02                              | Parameter copy                       | 0: Invalid<br>1: Upload parameters to LCD<br>2: Download | 0               | ◎      | PARA COPY          |

| Function Code | Name                         | Description  | Factory Setting | Modify | LCD Display    |
|---------------|------------------------------|--|-----------------|--------|----------------|
|               |                              | parameters from LCD  |                 |        |                |
| P7.03         | QUICK/JOG function selection | 0:Overhaul running (only for keypad control)<br>1: FDW/REV switching(only for keypad control)  | 0               | ☉      | QUICK/JOG FUNC |
| P7.04         | STOP/RST function selection  | 0: Valid when keypad control (P0.01=0)<br>1: Valid when keypad or terminal control (P0.01=0 or 1)<br>2: Valid when keypad or communication control (P0.01=0 or 2)<br>3: Always valid | 0               | ○      | STOP/RST FUNC  |
| P7.05         | Keypad display selection     | 0: Preferential to external keypad<br>1: Both display, only external keypad valid.<br>2: Both display, only local keypad valid.<br>3: Both display and keypad valid.                 | 0               | ○      | KEYPAD DISPLAY |

| Function Code | Name                            | Description   | Factory Setting | Modify | LCD Display     |
|---------------|---------------------------------|---|-----------------|--------|-----------------|
| P7.06         | Running state display selection | 1.Output speed<br>2.Reference speed<br>3.DC bus voltage<br>4.Output voltage<br>5.Output current<br>Other parameters display is determined by 16 bit binary digit<br>BIT0: Running frequency<br>BIT1: Rotation speed<br>BIT2: Output power<br>BIT3: Output torque<br>BIT4: Input terminal state<br>BIT5: Output terminal state<br>BIT6: AI1<br>BIT7: AI2<br>BIT8: Torque compensation<br>BIT9: Pole position<br>BIT10~ BIT15: Reserved | 0x00FF          | ○      | RUNNING DISPLAY |



| Function Code | Name                         | Description   | Factory Setting | Modify | LCD Display    |
|---------------|------------------------------|---|-----------------|--------|----------------|
| P7.07         | Stop state display selection | BIT0: Reference speed<br>BIT1: Reference frequency<br>BIT2: DC bus voltage<br>BIT3: Input terminal state<br>BIT4: Output terminal state<br>BIT5: Motor poles<br>BIT6: AI1<br>BIT7: AI2<br>BIT8: Pole position<br>BIT9: ~BIT15: Reserved | 0x00FF          | ○      | STOP DISPLAY   |
| P7.08         | Rectifier module temperature | 0~100.0°C   |                 | ●      | RECTIFIER TEMP |
| P7.09         | IGBT module temperature      | 0~100.0°C   |                 | ●      | IGBT TEMP      |
| P7.10         | MCU software version         | Factory setting   |                 | ●      | MCU VERSION    |
| P7.11         | DSP software version         | Factory setting   |                 | ●      | DSP VERSION    |
| P7.12         | Accumulated running time     | 0~65535h  |                 | ●      | TOTAL RUN TIME |

| Function Code | Name                    | Description   | Factory Setting | Modify | LCD Display      |
|---------------|-------------------------|---|-----------------|--------|------------------|
| P7.13         | Previous two fault type | 0: Not fault<br>1: IGBT Ph-U fault(OUT1)<br>2: IGBT Ph-V fault(OUT2)<br>3: IGBT Ph-W fault(OUT3)<br>4: Over-current when acceleration(OC1)  |                 | ●      | 3rd LATEST FAULT |
| P7.14         | Previous fault type     | 5: Over-current when deceleration(OC2)<br>6: Over-current when constant speed running (OC3)<br>7: Over-voltage when acceleration(OV1)<br>8: Over-voltage when deceleration(OV2)<br>9: Over-voltage when constant speed running(OV3)<br>10: DC bus Under-voltage(UV)<br>11: Motor overload |                 | ●      | 2nd LATEST FAULT |
| P7.15         | Current fault type      | (OL1)<br>12: Inverter overload (OL2)<br>13: Input phase failure (SPI)<br>14: Output phase failure (SPO)<br>15: Rectify overheat (OH1)   |                 | ●      | CURRENT FAULT    |

| Function Code | Name                              | Description   | Factory Setting | Modify | LCD Display |
|---------------|-----------------------------------|---|-----------------|--------|-------------|
|               |                                   | 16: IGBT overheat (OH2)<br>17: External fault (EF)<br>18: Communication fault (CE)<br>19: Current detection fault (ITE)<br>20: Autotuning fault (TE)<br>21: Encoder fault(PCE)<br>22: Encoder reverse fault(PCDE)<br>23: System fault(OPSE)<br>24: EEPROM fault (EEP)<br>25: Pole position check fault (PPCE)<br>26: Brake unit fault (BCE)<br>27: Trial time reached(END)<br>28: LCD disconnected(LCD-E)<br>29: Brake action fault(FAE)<br>30: Contactor feedback fault(TbE)<br>31: Speed bias is too large(dEV) |                 |        |             |
| P7.16         | Output frequency at current fault |   |                 | ●      | FAULT FREQ  |

| Function Code                      | Name   | Description   | Factory Setting | Modify | LCD Display             |
|------------------------------------|--|---|-----------------|--------|-------------------------|
| P7.17                              | Output current at current fault  |   |                 | ●      | FAULT CURR              |
| P7.18                              | DC bus voltage at current fault  |   |                 | ●      | FAULT DC VOLT           |
| P7.19                              | Input terminal state at current fault  |   |                 | ●      | FAULT Sx STATE          |
| P7.20                              | Output terminal state at current fault                                       |   |                 | ●      | FAULT DO STATE          |
| P7.21~P7.22                        | Reserved   | 0~65535   | 0               | ◎      | RESERVE                 |
| <b>P8 Group: Enhanced function</b> |  |   |                 |        |                         |
| P8.00                              | Analog weigh signal input selection  | 0: No function<br>1: AI1<br>2: AI2  | 0               | ◎      | ANALOG WEIGH INPUT      |
| P8.01                              | Pre-torque offset  | 0.0~100.0%  | 30.0%           | ○      | PREP TORQUE OFFSET      |
| P8.02                              | Drive side gain  | 0.000~7.000   | 1.000           | ○      | DRIVE PLUSE             |
| P8.03                              | Brake side gain  | 0.000~7.000   | 1.000           | ○      | BRAKE PLUSE             |
| P8.04                              | Brake, contactor control selection(only effective at terminals control mode) | 0: Invaild<br>1: Brake available, contactor inavailable<br>2: Brake inavailable contactor available<br>3: Brake and contactor available | 0               | ◎      | BRAKE CONTACTOR CONTROL |
| P8.05                              | Close brake delay time   | 0.00~5.00s  | 0               | ◎      | CLOSE BRAKE DELAY       |
| P8.06                              | Open brake delay   | 0.00~5.00s  | 0               | ◎      | OPEN                    |

| Function Code | Name  | Description               | Factory Setting | Modify | LCD Display                 |
|---------------|---|---------------------------|-----------------|--------|-----------------------------|
|               | time  |                           |                 |        | BRAKE DELAY                 |
| P8.07         | Brake threshold voltage                       | 320.0~750.0V              | 700.0V          | ○      | BRAKE THRE VOLT             |
| P8.08         | Fault auto reset times                        | 0~10                      | 0               | ○      | AUTO RESET TIMES            |
| P8.09         | Fault relay action                            | 0: Disabled<br>1: Enabled | 1               | ○      | FAULT ACTION                |
| P8.10         | Reset interval                                | 0.1~100.0s                | 1.0s            | ○      | RESET INTERVAL              |
| P8.11         | Contacting brake feedback inspecting interval | 0.1~5.0s                  | 2.0             | ◎      | BRAKE FEEDBACK INTERVAL     |
| P8.12         | Contacting feedback inspecting interval       | 0.1~5.0s                  | 2.0             | ◎      | CONTACTOR FEEDBACK INTERVAL |
| P8.13         | Stop contracting brake frequency              | 0.00~5.00Hz               | 0.00            |        |                             |
| P8.14         | Start DC brake current                        | 0.0~120%                  | 0.0             |        |                             |
| P8.15         | Start DC brake time                           | 0.0~50.0s                 | 0.0             |        |                             |
| P8.16         | Stop brake starting frequency                 | 0.00~P0.04                | 0.00            |        |                             |
| P8.17         | Stop brake waiting time                       | 0.0~50.0s                 | 0.0             |        |                             |
| P8.18         | Stop DC brake current                         | 0.0~120%                  | 0.0             |        |                             |
| P8.19         | Stop DC brake time                            | 0.0~50.0s                 | 0.0             |        |                             |
| P8.20         | Stopping delay                                | 0.0~50.0s                 | 0.0             |        |                             |
| P8.21         | Two/Three-phase modulation selection          | 0~1                       | 1               |        |                             |
| P8.21~P8.22   | Reserved                                      | 0~65535                   | 0               | ◎      | RESERVE                     |

| Function Code                        | Name                              | Description  | Factory Setting | Modify                           | LCD Display    |
|--------------------------------------|-----------------------------------|--|-----------------|----------------------------------|----------------|
| <b>P9 Group: Protection function</b> |                                   |  |                 |                                  |                |
| P9.00                                | Input phase-failure protection    | 0: Disabled<br>1: Enabled  | 1               | <input type="radio"/>            | IN PHASE FAIL  |
| P9.01                                | Output phase-failure protection   | 0: Disabled<br>1: Enabled  | 1               | <input type="radio"/>            | OUT PHASE FAIL |
| P9.02                                | Motor overload protection         | 0: Disabled<br>1: Normal motor(with the function of low speed compensation)<br>2: Variable frequency motor(without the function of low speed compensation)   | 2               | <input checked="" type="radio"/> | MOTOR OVERLOAD |
| P9.03                                | Motor overload protection current | 20.0%~120.0%   | 100.0%          | <input type="radio"/>            | OVERLOAD CURR  |
| P9.04                                | Overload pre-warning threshold    | 20.0%~150.0%   | 130.0%          | <input type="radio"/>            | OL WARN CURR   |
| P9.05                                | Overload pre-warning selection    | 0: Always detect relative to motor rated current<br>1: Detect while constant speed relative to motor rated current<br>2: Always detect relative to inverter rated current<br>3: Detect while constant speed relative to inverter rated current | 0               | <input checked="" type="radio"/> | OL WARN SELECT |
| P9.06                                | Overload pre-warning delay time   | 0.0~30.0s  | 5.0s            | <input type="radio"/>            | OL WARN DELAY  |

| Function Code                         | Name                              | Description   | Factory Setting | Modify                | LCD Display    |
|---------------------------------------|-----------------------------------|---|-----------------|-----------------------|----------------|
| P9.07                                 | Threshold of over speed deviation | 0.0%~50%  | 0.0~50          | 20.0 %                |                |
| P9.08                                 | Reserved                          | 0.000~10.000s   | 0.000~10.000    | 0.5000                | RESERVE        |
| <b>PA Group: Serial communication</b> |                                   |   |                 |                       |                |
| PA.00                                 | Local address                     | 1~247<br>0: broadcast address   | 1               | <input type="radio"/> | LOCAL ADDRESS  |
| PA.01                                 | Communication baud rate selection | 0: 1200BPS<br>1: 2400BPS<br>2: 4800BPS<br>3: 9600BPS<br>4: 19200BPS<br>5: 38400BPS  | 4               | <input type="radio"/> | BAUD RATE      |
| PA.02                                 | Data format                       | 0: No parity (8,N,2) for RTU<br>1: Even parity (8,E,1) for RTU<br>2: Odd parity (8,O,1) for RTU<br>3: No parity (8,N,2) for ASCII<br>4: Even parity (8,E,1) for ASCII<br>5: Odd parity (8,O,1) for ASCII<br>6: No parity (7,N,2) for ASCII<br>7: Even parity (7,E,1) for ASCII<br>8: Odd parity (7,O,1) for ASCII | 1               | <input type="radio"/> | DATA FORMAT    |
| PA.03                                 | Communication response delay time | 0~20ms  | 0               | <input type="radio"/> | COM DELAY TIME |

| Function Code                                    | Name  | Description                | Factory Setting | Modify | LCD Display        |
|--|---|----------------------------|-----------------|--------|--------------------|
| PA.04  | Communication timeout delay                       | 0.0(invalid)<br>0.1~100.0s | 0.0s            | ○      | COM<br>TIMEOUT     |
| PA.05  | Communication reply enabled selection`            | 0: Enabled<br>1: Disabled  | 0               | ○      | RESPONSE<br>ACTION |
| PA.06  | Reserved  | 1~127                      | 1               | ◎      | RESERVE            |
| PA.07  | Reserved  | 0~6                        | 4               | ◎      | RESERVE            |
| PA.08~<br>PA.11                                  | Reserved  | 0~65535                    | 0               | ◎      | RESERVE            |
| <b>Pb Group: Display monitor</b>                 |   |                            |                 |        |                    |
| Pb.00  | Running frequency                                 | 0.0~Maximum<br>frequency   |                 |        |                    |
| Pb.01  | Reserved  | 0~65535                    |                 |        |                    |
| Pb.02  | Pole position angle                               | 0.0~359.9                  |                 |        |                    |
| Pb.03  | Synchronizer static identify actual current value | 0.0%~200.0%                |                 |        |                    |
| Pb.04  | Mechanical angle                                  | 0.0~359.9                  |                 |        |                    |
| Pb.05  | Reserved  | Reserved                   |                 |        |                    |
| Pb.06  | AD detection value of encoder C phase             | 0~1024                     |                 |        |                    |
| Pb.07  | AD detection value of encoder D phase             | 0~1024                     |                 |        |                    |
| Pb.08~Pb.<br>09                                  | Reserved  | Reserved                   |                 |        | RESERVE            |
| <b>PC Group: No weighing starting parameters</b> |   |                            |                 |        |                    |
| PC.00  | No weighting compensation enable                  | 0:Disable<br>1:Enable      | 0               |        |                    |
| PC.01  | Load compensation time                            | 0.000~5.000s               | 0.500s          |        |                    |
| PC.02  | Load compensation                                 | 0.000~5.000s               | 0.300s          |        |                    |



| Function Code  | Name                                  | Description | Factory Setting | Modify    | LCD Display      |
|--|---------------------------------------|-------------|-----------------|-----------|------------------|
|  | lower time                            |             |                 |           |                  |
| PC.03  | Load compensation ASR proportion gain | 0~100       | 30              |           |                  |
| PC.04  | Load compensation ASR integral gain   | 0.01~10.00s | 0.04s           |           |                  |
| PC.05  | Position loop APR proportion gain     | 0~100       | 0               |           |                  |
| PC.06  | Position loop APR differential gain   | 0.01~10.00s | 0.00s           |           |                  |
| PC.07  | Current compensation coefficient      | 0~2000      | 1000            |           |                  |
| PC.08  | Current command filter coefficient    | 0~65536     | 0               |           |                  |
| <b>Pd Group: No weighting starting parameters (reserved)</b> |                                       |             |                 |           |                  |
| <b>PE Group: Factory function</b>                            |                                       |             |                 |           |                  |
| PE.00  | Factory password                      | 0~65535     | 0~65535         | ****<br>* | Factory password |

 **SHENZHEN INVT ELECTRIC CO., LTD.**  
Add: No. 4 Building , Gaofa Scientific Industrial Park, Longjing, Nanshan District, Shenzhen, China, 518055  
Tel: 86-755-86312804 Fax: 86-755-86312884  
E-mail: [overseas@invt.com.cn](mailto:overseas@invt.com.cn) [www.invt.com](http://www.invt.com)

---

INVT Copyright.

Information may be subject to change without notice during product improving.

V3.0